



AFM500X

Automatic Flashing Module



The Power-Tronics AFM500X Automatic Flashing Module is a convenient and compact optional build up module for all Power-Tronics UVR and XR series Universal Voltage Regulators. The AFM500X offers an automatic flash or battery flash mode on the same module for added versatility.

The AFM500X is a unique, automatic flashing module designed specifically for generators with very low AC residual voltage, brush-type generators, and for any installation where guaranteed buildup is required. Operation is completely automatic and installation into a Power-Tronics regulating system is quick and easy.

The two modes offered by the AFM500X are automatic flashing and battery flashing. Automatic flashing uses the existing residual AC voltage of the generator as a flashing source, while the battery flashing mode uses an external battery for its flashing source. All inputs are fused to protect any connected equipment!

Specifications

Input Voltage:	120 / 208 or 240vac
Frequency:	50-400Hz
Buildup Pullout Voltage:	85-100vac
Maximum Continuous Output:	5adc
Minimum Field Resistance:	21Ω
Min Residual Build up Voltage:	2vac
Under Frequency Protection:	Yes, VPH reduction
Physical Size:	3 x 4 x 1 in.
Weight:	7 oz
Repairable:	Yes
Internal Protection:	Fuses, cartridge type

Like the rest of our professional line of products, the AFM500X is fully repairable! None of the major electronic components are encapsulated to facilitate prompt repair! The entire unit is coated in a protective film to insulate it from any contamination and moisture that may be present.

The AFM500X Automatic Flashing Module is compatible with all previous UVR and XR series Universal Voltage Regulators as well as select VR series voltage regulators. The AFM500X is also a very simple upgrade for installations using older Power-Tronics BU120/240 or BU500 series buildup modules!



Table of Contents

Introduction and Functional Description:.....	3
Determining Which Hookup Configuration to Use:.....	4
Use With Power-Tronics Optional Static Exciter Modules:.....	5
Automatic Flashing Configuration:.....	6
Battery Flashing Configuration:.....	7
Initial Setup and Commissioning:.....	8
Internal Fuse Replacement:.....	9
Application Troubleshooting:.....	10
Bench Check Procedures:.....	11
Installation Warranty Form:.....	12
Product Warranty Certificate:.....	13



Introduction and Functional Description

Caution: Read This Installation Manual Carefully and Entirely!

Warning: Do not use digital equipment to read voltage, Hz, or amperage during this installation. Use only Analog sensing equipment! Failure to do so may result in damage to equipment or in personal injury!

ALWAYS perform all setup procedures off-line

ALWAYS wear eye protection

ALWAYS strip wire insulation properly or use insulated connectors

ALWAYS use analog metering equipment when setting up the regulator

ALWAYS ensure the AFM500X receives ample airflow

NEVER hold the AFM500X in your hand when energized

NEVER install the AFM500X in a place it can get wet or is exposed to the elements

NEVER mount the AFM500X over a screw, bolt, rivet, welding seam, or other fastener

NEVER remove the AFM500X backing while the unit is in operation

NEVER insert a screwdriver or other object under the AFM500X

NEVER install a switch in the DC portion of the regulator's wiring

NEVER touch any exposed part of the AFM500X while in operation

NEVER USE A DIGITAL FREQUENCY METER (It can give a false reading!)

Functional Description

The AFM500X Automatic Flashing Module is a proven design based on industry-standard flashing procedures and safety policies. The AFM500X provides a very compact automatic flashing or battery flashing source to any Power-Tronics voltage regulating system quickly, easily, and safely.

When the generator is first energized, the voltage regulator typically begins its buildup mode where it brings the generator up to a given point before it goes into its regulation mode. Sometimes, however, the generator may have extremely low residual AC voltage or just have a hard time building up. In these situations, the voltage regulator has a difficult time building up the voltage to a point it can regulate. The solution in most situations like this is to flash the generator.

The AFM500X provides two modes of flashing: Automatic and Battery. Automatic flashing is often used on generators with sliprings and brushes and for generators with very low residual AC voltage (typically less than 3VAC). Battery flashing is more often used on generators with no, or extremely low residual AC voltage (typically less than 1.5-2VAC) or in installations where a guaranteed buildup is required, such as hospitals, nursing homes, or correctional facilities.

The AFM500X Automatic Flashing Module is based on time-proven flashing methods and features an extremely robust and reliable design. Both voltage inputs and battery inputs are fused to protect both the AFM500X and any connected equipment in the unlikely event of a fault. Because of its simplicity and open design, the AFM500X is quickly and easily repaired should the need ever arise.



Determining Which Hookup Configuration to Use

STOP! This manual *ONLY* covers installation of the AFM500X Automatic Flashing Module! If you are using an optional Static Exciter Module, the installation of this product does not differ! Refer to the instructions that came with your optional modules for their correct wiring hookup.

The AFM500X is configurable for 2 different modes of operation:
Automatic Flashing, and **Battery Flashing**.

**YOU MUST CHOOSE ONE FLASHING METHOD OR THE OTHER!!
NEVER COMBINE THE TWO FLASHING METHODS! SEVERE
DAMAGE WILL RESULT!!!**

To determine the proper connection for your generator you need to know the residual AC voltage of your generator and which type of generator you have.

To determine the residual AC voltage of your generator, run engine with the voltage regulator turned off and measure the voltage produced at the AC input terminals of the voltage regulator then refer to the selection chart below:

When you have determined your residual AC voltage, select a Mode (Automatic or Battery Flash) from the chart below:

- Residual AC voltage is 2VAC or greater, or the generator has only occasional problems building up voltage. Use **Automatic Flash** (See Page 7)
 - Residual AC voltage is below 2VAC, the generator is a slip ring and brush type, or guaranteed buildup is required. Use **Battery Flash** (See Page 8)
-
-



Use With Power-Tronics Optional Power-Tronics Static Exciter Modules

The AFM500X Automatic Flashing Module can be used with Power-Tronics SE350, SE450, SE900 and SEM100A Static Exciter Modules. When installing the AFM500X in one of these conditions, you must follow the instructions in this manual precisely to prevent damage to the AFM500X!

The AFM500X should **NEVER** be connected directly to the exciter field when using an optional Static Exciter Module! Damage to the AFM500X will result!



Automatic Flash Configuration

This configuration uses the existing residual AC voltage from the generator stator to build the terminal voltage to a point that the automatic voltage regulator can take over and perform its function.

Take special care to follow the wiring directions precisely! DO NOT use the automatic flash configuration in conjunction with the battery flash configuration!

Note that the maximum input voltage to the AFM500X Automatic Flashing Module is 240VAC! DO NOT input 277VAC into the AFM500X! Severe damage to the unit will result! For use on 480V systems, either connect the regulator to the winding center taps T7 and T8 or use a 480-240V step-down transformer.

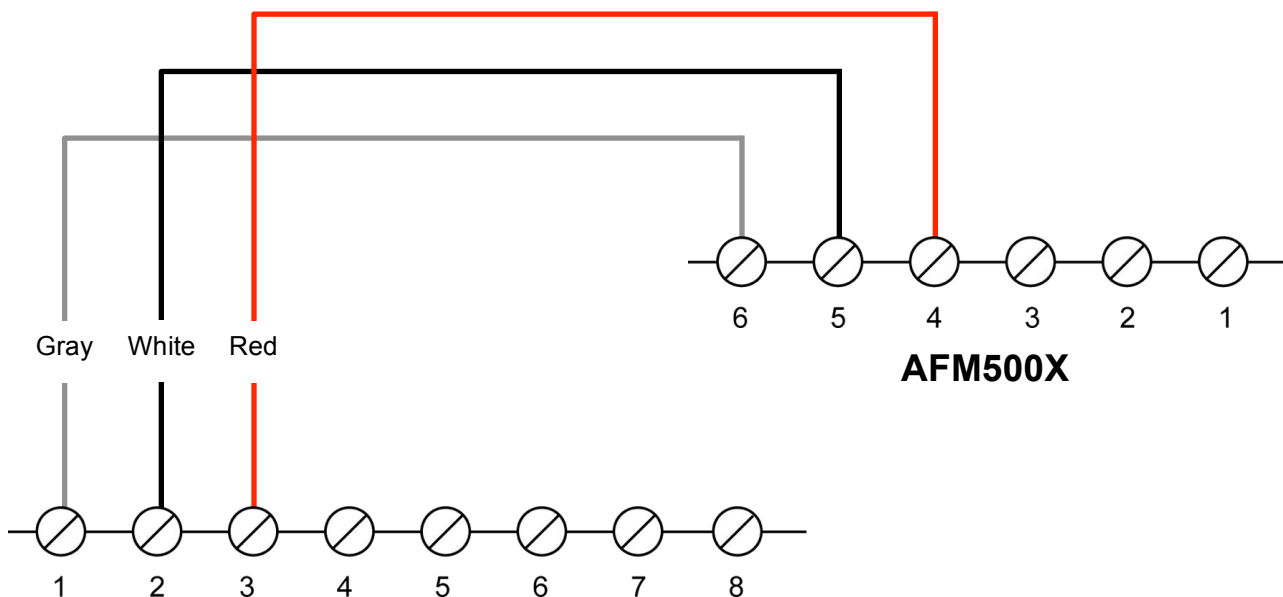

XR or UVR series Universal Voltage Regulator †

NOTE: Wiring from the AFM500X must ALWAYS be connected to the voltage regulator terminal board regardless of any other optional modules in use!

† Refer to your instructions that came with your Universal Voltage Regulator for the interconnect diagrams to connect your voltage regulator to your generator.



Battery Flashing Configuration

This configuration uses an external battery source to build the terminal voltage to a point that the automatic voltage regulator can take over and perform its function. This configuration should be used on brush-type generators as well as installations that require a guaranteed voltage buildup such as hospitals and correctional facilities.

Take special care to follow the wiring directions precisely! DO NOT use the battery flash configuration in conjunction with the automatic flash configuration!

Note that the maximum input voltage to the AFM500X Automatic Flashing Module is 240VAC! DO NOT input 277VAC into the AFM500X! Severe damage to the unit will result! For use on 480V systems, either connect the regulator to the winding center taps T7 and T8 or use a 480-240V step-down transformer.

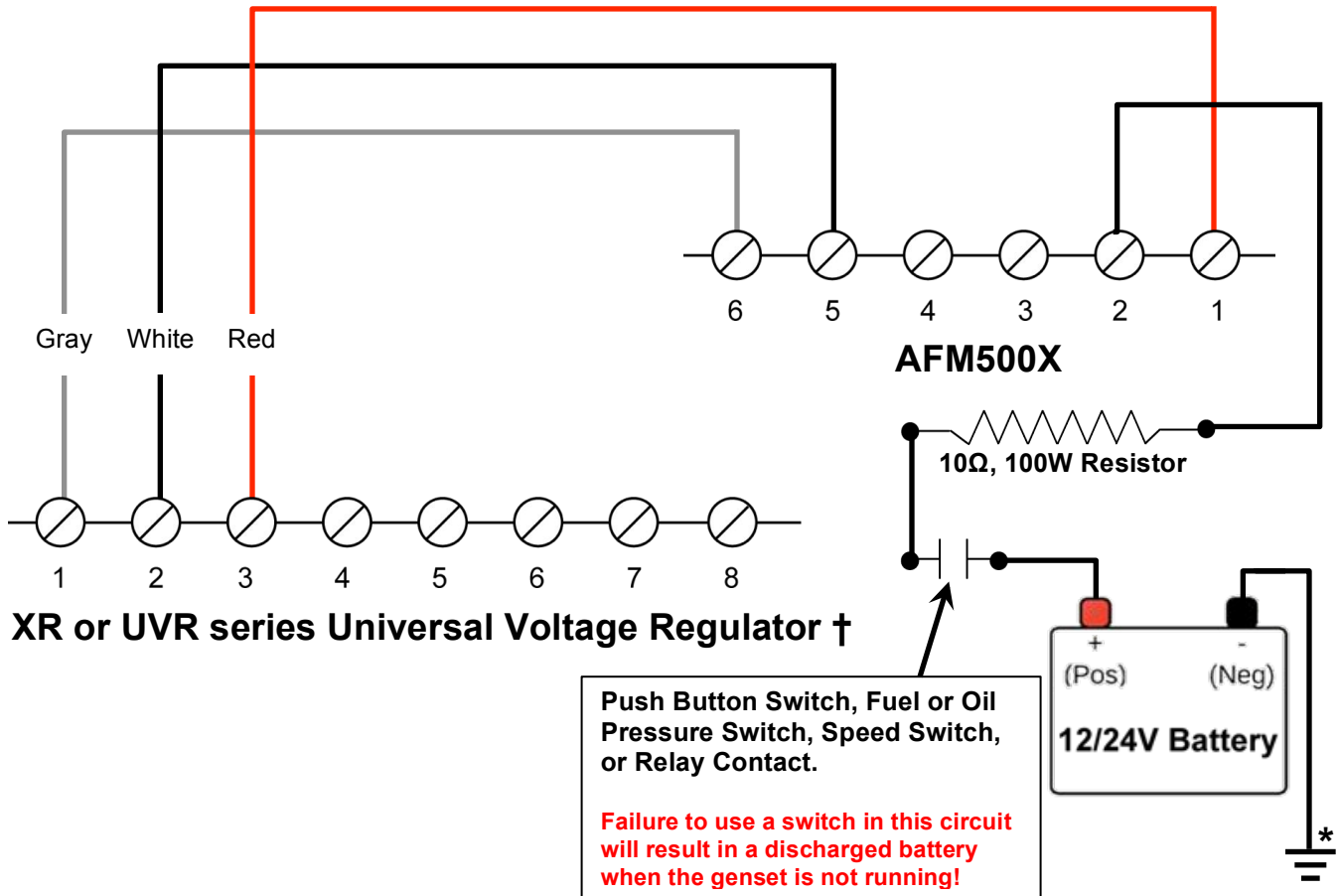

NOTE: Wiring from the AFM500X must ALWAYS be connected to the voltage regulator terminal board regardless of any other optional modules in use!

† Refer to your instructions that came with your Universal Voltage Regulator for the interconnect diagrams to connect your voltage regulator to your generator.

* Battery Negative must be connected to the generator Neutral or T0 and NOT to F- of the exciter!



Initial Setup and Commissioning

1. Refer to your voltage regulator's instruction manual for initial setup and commissioning of the voltage regulator.
2. If using the Automatic-Flash configuration, follow the initial setup and commissioning instructions of your voltage regulator as shown in the voltage regulator's instruction manual.
3. If using the Battery-Flash configuration, follow the initial setup and commissioning instructions of your voltage regulator as shown in the voltage regulator's instruction manual, except energize or turn on the switch to the AFM500X when you plan to energize the generator during setup.
4. Observe the buildup operation and verify there is no excessive voltage overshoot and that the voltage regulator is operating properly.
5. If using the Battery-Flash configuration, always remember to open the switch or relay contact connected to the AFM500X when shutting the generator down. This will prevent a drained battery when the generator is stored.
6. When you are satisfied with the buildup performance of the generator, the setup and commissioning is complete.



Fuse Replacement

The AFM500X contains 3 glass cartridge fuses located for quick and convenient replacement should they blow. To replace the fuses, follow the instructions below.

Fuse size is 20mm x 5mm rated at 5A at 250VAC.

Power-Tronics Part Number: 5R3-403 (Comes as a package of 10 fuses)

Cooper-Bussmann Part Number: BK/GDB-5A

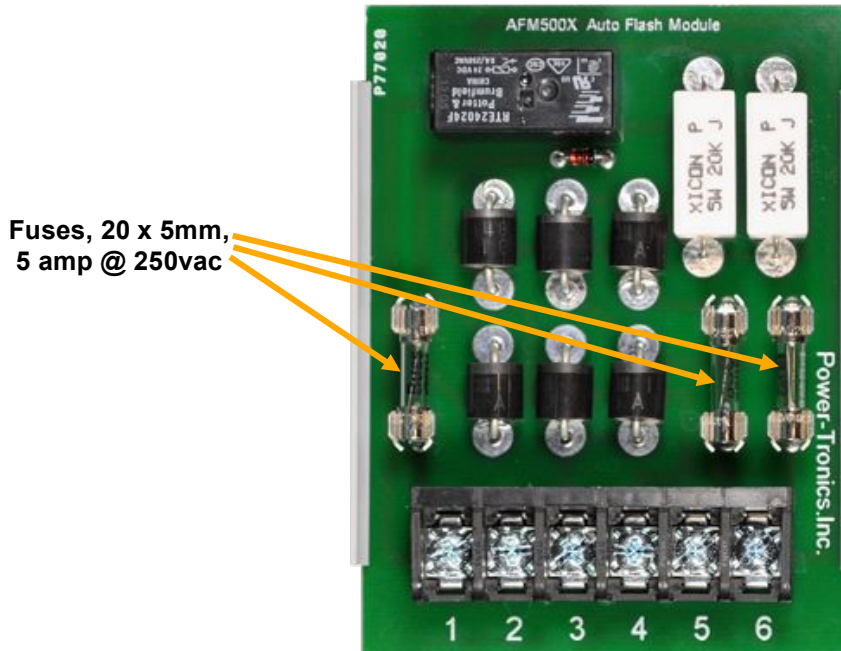

Fuse Replacement Procedure:

(Refer to the image above for easy reference)

- Visually Check each fuse for signs of failure. A melted fuse link or darkened window will indicate failure. Check each of the 3 fuses for continuity with a multimeter. They will conduct if good, but will not if open.
- Replace open fuses with exact replacement fuses.
- Fuse size is 20mm x 5mm, 5A @ 250VAC. **(DO NOT REPLACE WITH ANY OTHER TYPE OR RATING OF FUSE! YOU WILL VOID YOUR WARRANTY AND SEVERE DAMAGE AND PERSONAL INJURY COULD RESULT BY DOING SO!)**



Application Troubleshooting

Problem:	Possible Cause
No Voltage	1 3 5 7 9 11 13 15 20 22
Pulsating Voltage	4 5 6 12 16
Flickering Voltage	4 6 7 14
High Voltage	6 7 8 9 12 13 17 18 20 21
Voltage Drop on Load	5 8 10 12 16
Low Voltage	1 5 8 12 13
Poor Voltage Regulation	2 4 10 12 13 16
No Voltage Control	1 13 19 20 21

Possible Causes:

1. Open or loose connection, poor brush and slip ring contact, fuses are open in the regulator or AFM500X.
2. Unbalanced generator load.
3. Open exciter field or defective generator.
4. Non linear load or defective connection in exciter field.
5. Open diode in exciter or shorted rotor in generator.
6. Loose component in voltage regulator.
7. Loose wiring connections.
8. Input voltage to regulator is too low.
9. Exciter field is grounded.
10. Non linear load or wrong selection for regulator hookup.
11. Exciter fields are reversed.
12. Wrong selection of regulator wiring configuration.
13. Defective voltage regulator.
14. SCR or Inverter drive effecting generator waveform.
15. Regulator needs external flashing circuit.
16. Isolation transformer is too small.
17. Isolation transformer is needed.
18. Exciter fields are not isolated from other circuits.
19. Input and field circuit are being fed by a common cable or conduit.
20. Incorrect hookup or wiring.
21. Exciter field is grounded.
22. Drained battery (Only applies to Battery-Flash configuration).



Bench Check Procedures

NOTE: Testing the AFM500X requires access to a Vari-AC

1. Wire up the AFM500X as shown in Figure A.
2. Connect up a 120 volt 50 to 150 watt light bulb to the #4 and #3 Terminals.
3. Input 120vac from a Vari-AC into the AFM500X at #6 and #5. (Fuse this input with fuses rated at 120 volts or higher and not more than 5 amps ac). Slowly raise the voltage on the Vari-AC to 120VAC.
4. **Observation:** The light bulb should increase in brightness until you reach approximately 85-100VAC. At no more than 100VAC, the AFM500X should open the connection to the light bulb and it should go out. **NOTE: Relay chatter during this test is normal!**
5. Turn off power to the AFM500X and remove the light bulb from terminals #4 and #3.
6. Connect up the AFM500X as shown in Figure B and perform all of the previous steps again. **You should have the same results as in step 4!**
7. **If you were able to successfully perform all of these tests, the AFM500X is good.**

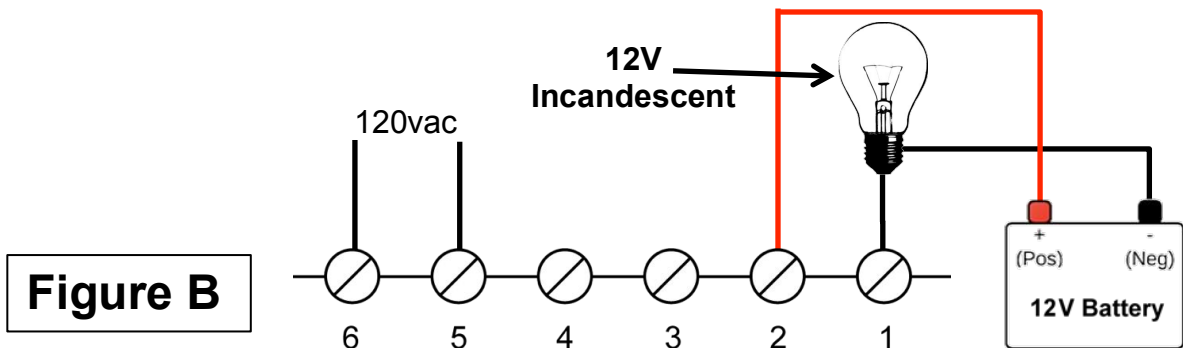
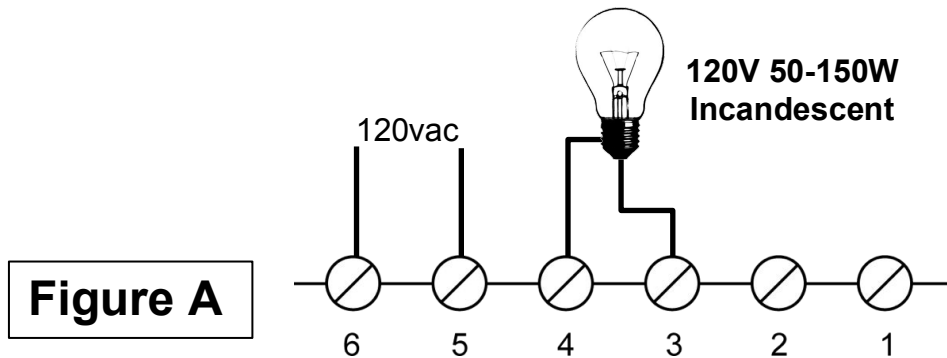



Installation Warranty Form

It is very important that you fill out this form completely when installing a voltage regulator. This form serves as a history record on the application. This form also contains the information needed by Power-Tronics, Inc., for repair and troubleshooting of any product you may be having problems with.

Failure to fill out this form during installation will result in a cancellation of your warranty coverage! Filling out this form takes only minutes but will save hours or days later on if your product should require service!

Product		Other options			
Serial Number					
Date of Installation					
Type of Generator				Model #	
		Brush type	<input type="checkbox"/>		
		Brushless	<input type="checkbox"/>		
AC Stator Information					
Wired for	Volts	Phase	Hz		
Generator Configuration: Lead					
Exciter/Rotor Information					
Exciter field resistance		Ω		@ F+ / F-	Ω
Exciter field volts		vdc		@ Slip Rings	Ω
Description of problem with product or generator					
Your phone number			Name:		
Your fax number			Ship to Address:		
Your email address			Ship to City, State, Zip:		



PRODUCT WARRANTY

Power-Tronics, Inc., assumes no liability for damages due to incorrect voltage or other voltage related damages resulting from either output of the generator or input to the generator exciter system. These problems should be protected with external devices provided by the customer such as **fuses, surge suppressors, over/under voltage and frequency controls.**

Power-Tronics, Inc., warranties **only parts and workmanship** of this product for a **period of 2 years from the original date of purchase from Power-Tronics, Inc.** Under warranty, Power-Tronics, Inc. will replace, exchange or repair the defective product **without labor or parts cost to the customer.** Remaining warranty of the original product will be transferred to the replaced or repaired product. To obtain warranty, a copy of the original Installation Warranty Form must be sent in with the defective product, which clearly shows the purchase date and serial number of the defective part. A repair request form must be sent in with the product before repairs will begin. You can obtain this form by contacting Power-Tronics, Inc.

Send repairs to: Power-Tronics, Inc., 2802 Cobbler Ln., Kerrville Texas USA 78028.

***Send in repairs only by UPS or FedEx.* USPS will NOT deliver to our facility!**

Any one of the following conditions will void the warranty:

- ❖ Overheating of the power supply resistor on the printed circuit card.
- ❖ Overheating of the SCR or freewheeling diode.
- ❖ Physical damage to the printed circuit card, housing or components.
- ❖ Unauthorized repair or alteration of printed circuit card.
- ❖ Installation by anyone other than a qualified professional generator service technician.
- ❖ Conductive or corrosive contamination of the circuit card.
- ❖ Removal of our company identification from the product.
- ❖ Removal of any conformal coating of the printed circuit card or components.
- ❖ Overheating of foil on the printed circuit card.
- ❖ Inappropriate or infeasible application.
- ❖ Use with any external device other than manufactured by Power-Tronics, Inc.
- ❖ Failure to fill out the attached warranty card during installation

No other warranty is expressed or implied.