

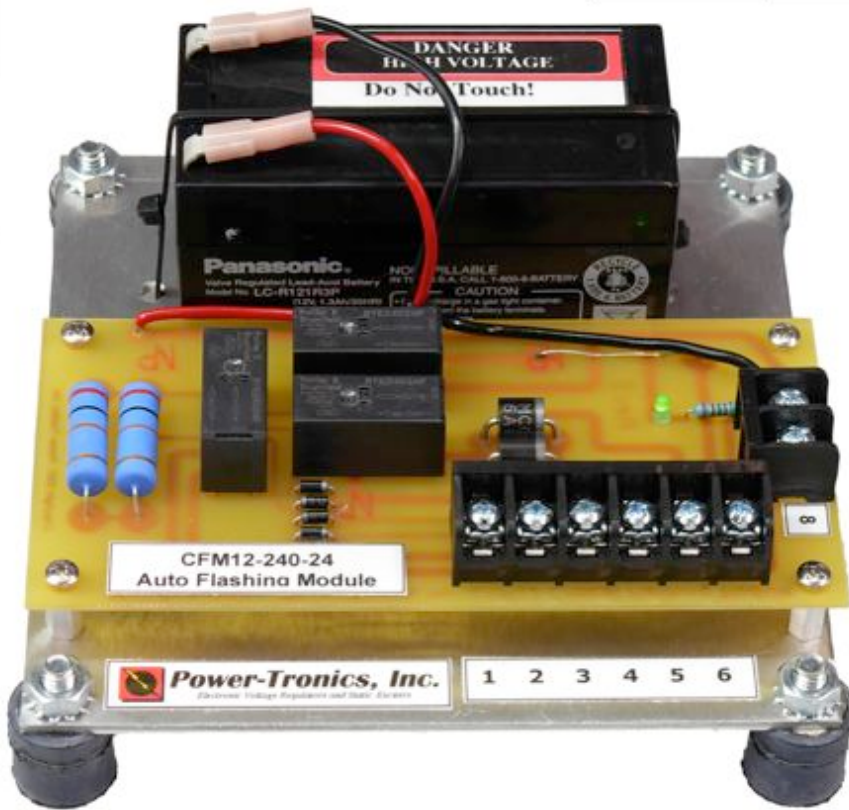

CFM12

Critical Flashing Module



The Power-Tronics CFM12 Critical Flashing Module is a convenient and compact optional build up module for all Power-Tronics UVR and XR series Universal Voltage Regulators. The CFM12 offers an easy method to add a fully automatic battery flashing unit to any generator.

The CFM12 is a unique Critical Flashing Module designed specifically for generators with very low AC residual voltage, brush-type generators, and for any installation where guaranteed buildup is required. Operation is completely automatic and installation into a Power-Tronics regulating system is quick and easy.

Like the rest of our professional line of products, the CFM12 is fully repairable! None of the major electronic components are encapsulated to facilitate prompt repair! The entire unit is coated in a protective film to insulate it from any contamination and moisture that may be present.

The CFM12 Critical Flashing Module is compatible with all previous UVR and XR series Universal Voltage Regulators as well as select VR series voltage regulators. The CFM12 is also a very simple upgrade for installations using older Power-Tronics BU120/240 or BU500 series buildup modules!

Specifications

Input Voltage:	120 / 208 or 240vac
Frequency:	50-400Hz
Buildup Pullout Voltage:	85-100vac
Output Voltage:	12vdc
Signal Input Voltage:	12 / 24 / 36vdc*
Maximum Continuous Output:	16adc
Minimum Field Resistance:	1Ω
Storage Device:	Rechargeable, Sealed Battery
Battery Charger Input Voltage:	120 / 240vac*
Physical Size:	6 x 6 x 3 in.
Weight:	3 lbs
Repairable:	Yes

* Voltage **MUST** be specified when placing order!



Table of Contents

Introduction and Functional Description:.....	3
Hookup Diagram:.....	4
Initial Setup and Commissioning:.....	5
Application Troubleshooting:.....	6
Bench Check Procedures:.....	7
Installation Warranty Form:.....	8
Product Warranty Certificate:.....	9



Introduction and Functional Description

Caution: Read This Installation Manual Carefully and Entirely!

Warning: Do not use digital equipment to read voltage, Hz, or amperage during this installation. Use only Analog sensing equipment! Failure to do so may result in damage to equipment or in personal injury!

ALWAYS perform all setup procedures off-line

ALWAYS wear eye protection

ALWAYS strip wire insulation properly or use insulated connectors

ALWAYS use analog metering equipment when setting up the regulator

ALWAYS ensure the CFM12 receives ample airflow

NEVER hold the CFM12 in your hand when energized

NEVER install the CFM12 in a place it can get wet or is exposed to the elements

NEVER mount the CFM12 over a screw, bolt, rivet, welding seam, or other fastener

NEVER remove the CFM12 backing while the unit is in operation

NEVER insert a screwdriver or other object under the CFM12

NEVER install a switch in the DC portion of the regulator's wiring

NEVER touch any exposed part of the CFM12 while in operation

NEVER USE A DIGITAL FREQUENCY METER (It can give a false reading!)

Functional Description

The CFM12 Critical Flashing Module is a proven design based on industry-standard flashing procedures and safety policies. The CFM12 provides a very compact automatic flashing or battery-flashing source to any Power-Tronics voltage regulating system quickly, easily, and safely.

When the generator is first energized, the voltage regulator typically begins its buildup mode where it brings the generator up to a given point before it goes into its regulation mode. Sometimes, however, the generator may have extremely low residual AC voltage or just have a hard time building up. In these situations, the voltage regulator has a difficult time building up the voltage to a point it can regulate. The solution in most situations like this is to flash the generator.

The CFM12 provides a fully automatic method to flash the generator during startup. Automatic flashing is often used on generators with sliprings and brushes and for generators with very low residual AC voltage (typically less than 3VAC) or in installations where a guaranteed buildup is required, such as hospitals, nursing homes, or correctional facilities.

The CFM12 Critical Flashing Module is based on time-proven flashing methods and features an extremely robust and reliable design. Both voltage inputs and battery inputs are unfused to attempt to force buildup even during a fault condition. Because of its simplicity and open design, the CFM12 is quickly and easily repaired should the need ever arise.



Hookup Diagram

This configuration uses the onboard 12V battery to build the terminal voltage to a point that the automatic voltage regulator can take over and perform its function. The CFM12 will automatically disconnect itself when the sensed voltage reaches approximately 90vac.

Take special care to follow the wiring directions precisely! DO NOT use a signal voltage different from that marked on the CFM12 unit! Severe damage to the CFM12 will result!

Note that the maximum input voltage to the CFM12 Critical Flashing Module is 240VAC! DO NOT input 277VAC into the CFM12! Severe damage to the unit will result! For use on 480V systems, either connect the regulator to the winding center taps T7 and T8 or use a 480-240V step-down transformer.

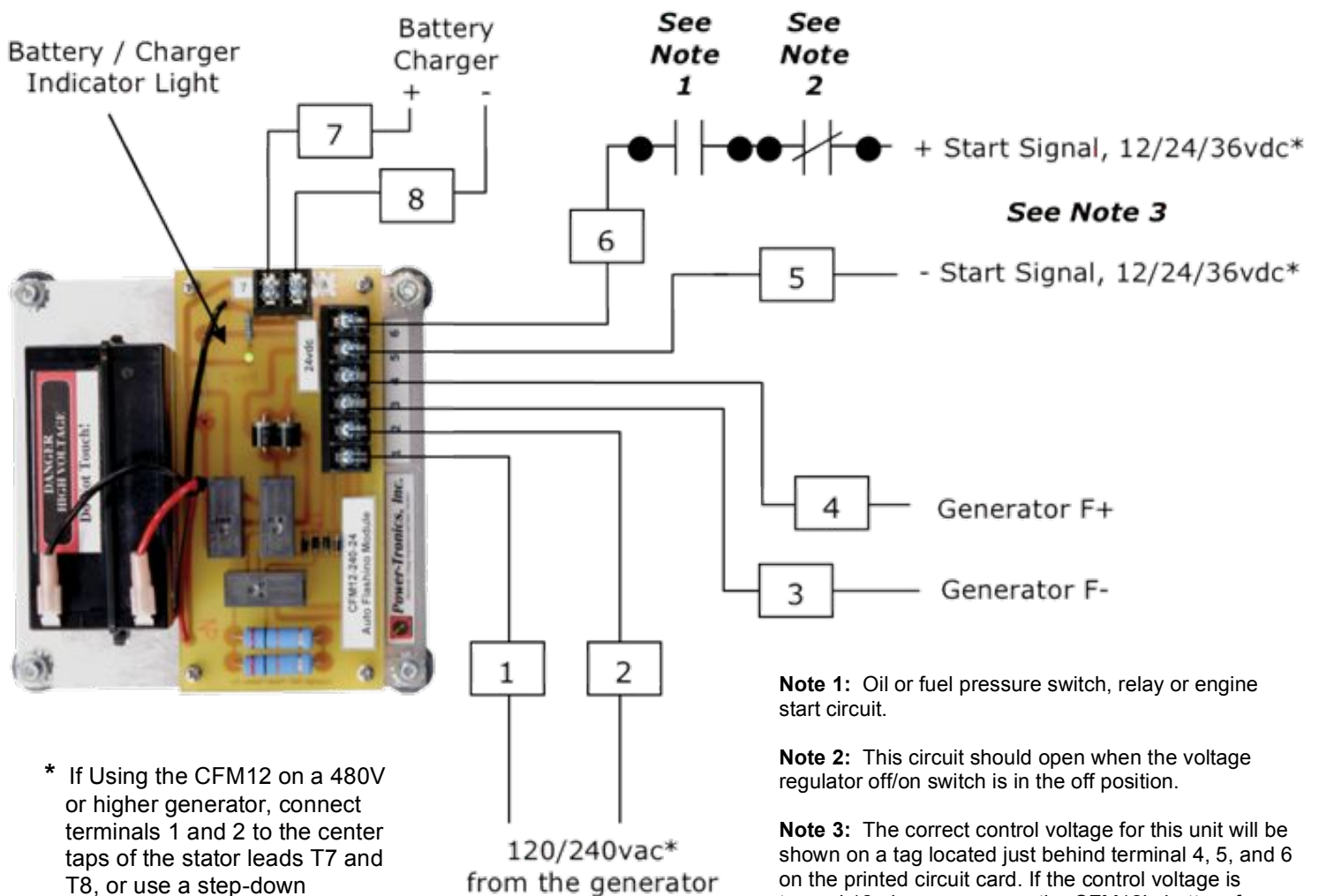

* If Using the CFM12 on a 480V or higher generator, connect terminals 1 and 2 to the center taps of the stator leads T7 and T8, or use a step-down transformer as appropriate to supply 240vac to the CFM12.

Note 1: Oil or fuel pressure switch, relay or engine start circuit.

Note 2: This circuit should open when the voltage regulator off/on switch is in the off position.

Note 3: The correct control voltage for this unit will be shown on a tag located just behind terminal 4, 5, and 6 on the printed circuit card. If the control voltage is tagged 12vdc, you can use the CFM12's battery for your control voltage source. (Terminal #7+, and #8-)



Initial Setup and Commissioning

1. Refer to your voltage regulator's instruction manual for initial setup and commissioning of the voltage regulator.
2. Remove the red lead from the Positive terminal on the CFM12's internal battery.
3. Install the battery charger supplied with the CFM12 as shown in the hookup diagram on page 4. The terminals on the battery charger leads will be marked, generally with the positive terminal being painted red and/or the negative terminal being painted black. If there is no marking on your terminals, the striped or ribbed wire is positive and the smooth or unmarked wire is negative.
4. Observe the indicator light on the CFM12 circuit card. It should glow green if the battery charger is correctly connected. If the indicator is glowing, reconnect the red lead to the positive terminal on CFM12's internal battery.
5. Wire the CFM12 into your generator and regulating system as shown in the hookup diagram on page 4. The CFM12 is capable of being used on generators with field resistances down to 1 Ω . If your field is lower resistance and you wish to use a CFM12, please contact Power-Tronics for an alternate wiring diagram.
6. Verify that your wiring is correct, and then proceed to test the generator for proper buildup. When satisfactory buildup is achieved installation is complete.



Application Troubleshooting

Problem:	Possible Cause
No Voltage	1 3 5 7 9 11 13 15 20 22
Pulsating Voltage	4 5 6 12 16
Flickering Voltage	4 6 7 14
High Voltage	6 7 8 9 12 13 15 17 18 20 21
Voltage Drop on Load	5 8 10 12 16
Low Voltage	1 5 8 12 13
Poor Voltage Regulation	2 4 10 12 13 16
No Voltage Control	1 13 15 19 20 21

Possible Causes:

1. Open or loose connection, poor brush and slip ring contact, fuses are open in the regulator.
2. Unbalanced generator load.
3. Open exciter field or defective generator.
4. Non linear load or defective connection in exciter field.
5. Open diode in exciter or shorted rotor in generator.
6. Loose component in voltage regulator.
7. Loose wiring connections.
8. Input voltage to regulator is too low.
9. Exciter field is grounded.
10. Non linear load or wrong selection for regulator hookup.
11. Exciter fields are reversed.
12. Wrong selection of regulator wiring configuration.
13. Defective voltage regulator.
14. SCR or Inverter drive effecting generator waveform.
15. Defective CFM12 Critical Flashing Module.
16. Isolation transformer is too small.
17. Isolation transformer is needed.
18. Exciter fields are not isolated from other circuits.
19. Input and field circuit are being fed by a common cable or conduit.
20. Incorrect hookup or wiring.
21. Exciter field is grounded.
22. Drained battery.



Bench Test Procedure

The CFM12 Critical Flashing Module contains no user-serviceable parts other than the battery.

If you suspect a problem with your CFM12 check the battery and its charger for proper operation. If the battery and charger prove to be operating normally, please contact Power-Tronics for troubleshooting assistance!



Installation Warranty Form

It is very important that you fill out this form completely when installing a voltage regulator. This form serves as a history record on the application. This form also contains the information needed by Power-Tronics, Inc., for repair and troubleshooting of any product you may be having problems with.

Failure to fill out this form during installation will result in a cancellation of your warranty coverage! Filling out this form takes only minutes but will save hours or days later on if your product should require service!

Product		Other options		
Serial Number				
Date of Installation				
Type of Generator			Model #	
	Brush type	<input type="checkbox"/>		
	Brushless	<input type="checkbox"/>		
AC Stator Information				
Wired for	Volts	Phase	Hz	
Generator Configuration: Lead				
Exciter/Rotor Information				
Exciter field resistance		Ω	@ F+ / F-	Ω
Exciter field volts		vdc	@ Slip Rings	Ω
Description of problem with product or generator				
Your phone number		Name:		
Your fax number		Ship to Address:		
Your email address		Ship to City, State, Zip:		



PRODUCT WARRANTY

Power-Tronics, Inc., assumes no liability for damages due to incorrect voltage or other voltage related damages resulting from either output of the generator or input to the generator exciter system. These problems should be protected with external devices provided by the customer such as **fuses, surge suppressors, over/under voltage and frequency controls.**

Power-Tronics, Inc., warranties **only parts and workmanship** of this product for a **period of 2 years from the original date of purchase from Power-Tronics, Inc.** Under warranty, Power-Tronics, Inc. will replace, exchange or repair the defective product **without labor or parts cost to the customer.** Remaining warranty of the original product will be transferred to the replaced or repaired product. To obtain warranty, a copy of the original Installation Warranty Form must be sent in with the defective product, which clearly shows the purchase date and serial number of the defective part. A repair request form must be sent in with the product before repairs will begin. You can obtain this form by contacting Power-Tronics, Inc.

Send repairs to: Power-Tronics, Inc., 2802 Cobbler Ln., Kerrville Texas USA 78028.

***Send in repairs only by UPS or FedEx.* USPS will NOT deliver to our facility!**

Any one of the following conditions will void the warranty:

- ❖ Overheating of the power supply resistor on the printed circuit card.
- ❖ Overheating of the SCR or freewheeling diode.
- ❖ Physical damage to the printed circuit card, housing or components.
- ❖ Unauthorized repair or alteration of printed circuit card.
- ❖ Installation by anyone other than a qualified professional generator service technician.
- ❖ Conductive or corrosive contamination of the circuit card.
- ❖ Removal of our company identification from the product.
- ❖ Removal of any conformal coating of the printed circuit card or components.
- ❖ Overheating of foil on the printed circuit card.
- ❖ Inappropriate or infeasible application.
- ❖ Use with any external device other than manufactured by Power-Tronics, Inc.
- ❖ Failure to fill out the attached warranty card during installation

No other warranty is expressed or implied.