



## DC250 DC Voltage Regulator

The Power-Tronics DC250 DC Voltage Regulator is the latest upgrade for all Power-Tronics DC and XR series DC voltage regulators. The DC250 is also capable of replacing other manufacturers' voltage regulators or existing manually operated controls!

The DC250 is a unique, DC Voltage Regulator that is designed specifically for replacement of vintage or obsolete DC generator voltage regulation equipment such as manually operated rheostats and/or resistor banks and offers precise voltage regulation regardless of the connected load and ambient temperature. The DC250 is a ruggedized design and is engineered to provide a lifetime of trouble-free operation.

PLC and automated control is possible with the DC250 by simply adding an optional, inexpensive digital interface module. This capability makes the DC250 suitable for automated or unattended installations.

The DC250 DC Voltage Regulator has a unique modular design to increase reliability and facilitate repair should the need ever arise. The DC250 is made up for separate control and firing modules and contains a user-replaceable field flashing relay. Because of its modular design, the DC250 DC Voltage Regulator can be fitted with rectifier modules of varying amperage capacity from 10adc to 40adc to meet the needs of a wide array of DC generators!

The DC250 is compatible with all previous and current optional modules available for use with Power-Tronics voltage regulators making it extremely simple to upgrade an older voltage regulator installation with the modern features offered by the DC250.

### Specifications

Input Voltage:	200-250vdc
Frequency:	DC
Voltage Regulation:	+/- 1% From NL to FL
Parallel Operation	No
Output Voltage:	0-250vdc @ 250vac input
Maximum Continuous Output:	10 / 20 / 40adc*
Minimum Field Resistance:	25Ω @ 10adc output* 10Ω @ 25adc output* 6.25Ω @ 40adc output*
Min Residual Build up Voltage:	5vdc
Physical Size:	10 x 10 x 4 in.
Weight:	4 lb.
External Protection:	Customer-Supplied Fuses
External Voltage Adjustment:	Yes
Optional External Controls	Yes

**\*Amperage must be specified when ordering! Default amperage configuration is 20adc!**



## Table of Contents

Introduction and Functional Description:.....	3
Determining Correct Application Sizing:.....	4
Conversion From Shunt-Wound to Solid-State Voltage Regulation:.....	6
Hookup Diagram:.....	7
Initial Setup and Commissioning:.....	8
Optional Power-Tronics Add-On Modules:.....	9
Application Troubleshooting:.....	10
Bench Check Procedures:.....	11
Installation Warranty Form:.....	12
Product Warranty Certificate:.....	13



## Introduction and Functional Description

# Caution: Read This Installation Manual Carefully and Entirely!

---

**Warning:** Do not use digital equipment to read voltage or amperage during this installation. Use only Analog sensing equipment! Failure to do so may result in damage to equipment or in personal injury!

**ALWAYS** perform all setup procedures off-line

**ALWAYS** wear eye protection

**ALWAYS** strip wire insulation properly or use insulated connectors

**ALWAYS** use analog metering equipment when setting up the regulator

**ALWAYS** ensure the regulator receives ample airflow

**NEVER** hold the regulator in your hand when energized

**NEVER** install the regulator in a place it can get wet or is exposed to the elements

**NEVER** mount the regulator over a screw, bolt, rivet, welding seam, or other fastener

**NEVER** remove the regulator cover while the unit is in operation

**NEVER** install a switch in the DC field portion of the regulator's wiring

---

## Functional Description

The DC250 DC Voltage Regulator is the result of over 20 years of engineering efforts and offers a difficult to obtain product with a very short lead-time and competitive price. The DC250 is a proven design and is engineered to greatly simplify setup while offering extreme reliability. When properly installed, the DC250 DC Voltage Regulator is designed to provide a lifetime of service.

A generator voltage regulator has several automated tasks it must perform in order to provide reliable, clean, and regulated electricity. It must build-up the generator and regulate the terminal voltage within its design specifications. The DC250 DC Voltage Regulator is intended to be quickly repaired in the field should a failure or fault occur thanks to its modular design.

The DC250 contains a time-proven, extremely reliable circuit for build-up functionality. Due to its simplicity, the DC250 is able to build up generators with residual voltages from 5vdc without initial overshoot or excessive delay. The DC250 is also a precision voltage regulator and is capable of regulating the terminal voltage of the generator within +/-1% of its initial set point.

Due to its extreme simplicity, the DC250 DC Voltage Regulator is uncommonly reliable and offers features and regulation accuracy usually only offered by much more complicated and often much more expensive regulators.



## Determining Correct Application Sizing

The DC250 DC Voltage Regulator is configurable for 3 different output amperage ranges suitable for use on the vast majority of generators available on the market from past and present. It is necessary to choose the proper amperage capacity for your generator in order to provide the best regulation and greatest reliability possible.

To determine the proper amperage capacity for your generator you need to know any two of the following 3 specifications from the rating plate of your generator:

- 1: Exciter Field Voltage (in DC Volts) [Generally given in full load Voltage on nameplates]
- 2: Exciter Field Resistance (in Ohms)
- 3: Exciter Field Amperage (in DC Amps) [Generally given in full load Amps on nameplates]

**Using the specifications obtained from your generator exciter, select a Compatible DC Rectifier Module (10, 25, or 40 amp) from the chart or graph below:**

- Field resistance is more than 25 ohms and field voltage is rated at 240vdc or less at full load. **Order DC250 with FM250-10 DC Rectifier Module**
- Field resistance is more than 10 ohms and field voltage is rated at 240vdc or less at full load. **Order DC250 with FM250-25 DC Rectifier Module**
- Field resistance is more than 6.25 ohms and field voltage is rated at 240vdc or less at full load. **Order DC250 with FM250-40 DC Rectifier Module**

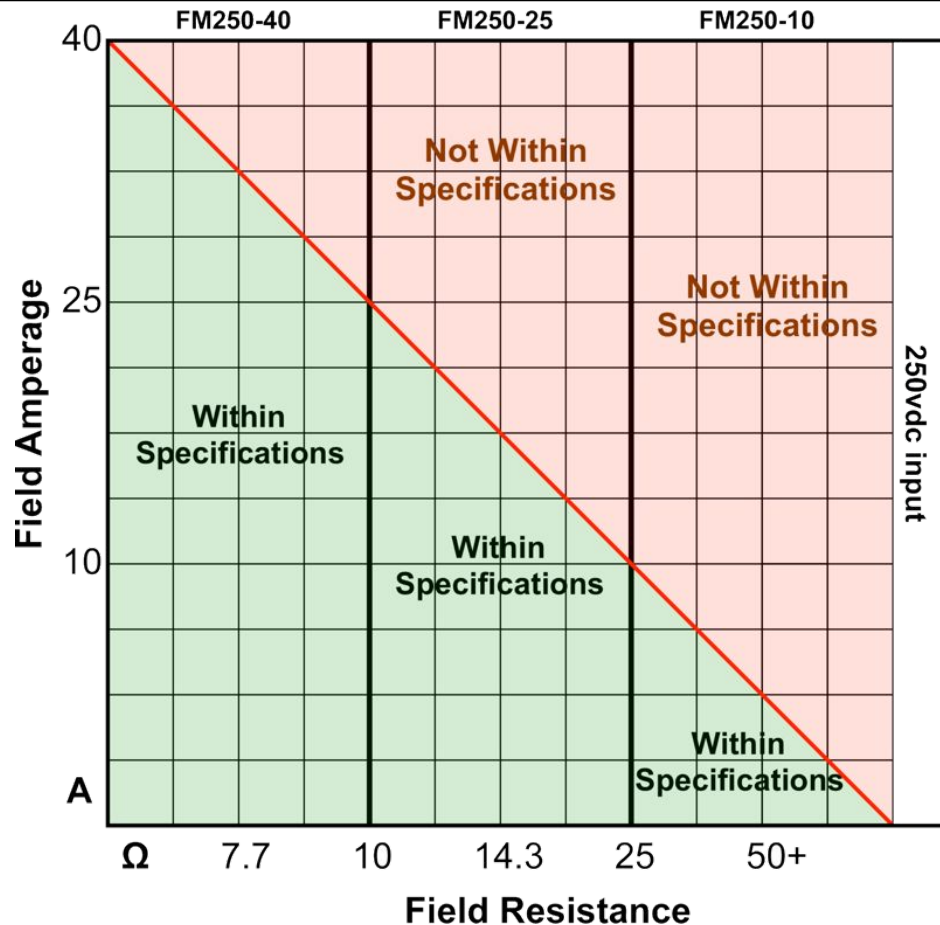



## Note About Brushes:

- Arcing brushes, poor brush contact, burned commutator segments, high bars, or incorrect neutral plane alignment will cause severe damage to the DC250 DC Voltage Regulator. Before installing the DC250, inspect your commutator and brushes for signs of commutation problems and signs of arcing. **Failure to correct brush and/or commutation problems will result in severe damage to the voltage regulator as well as possible PERMANENT damage to the commutator segments themselves!** NEVER use emery cloth, carborundum stones, “comm sticks”, or Tuner cleaner to dress or clean the commutator. They will make a bad problem much, much worse! Only use Garnet or Flint sandpaper and clean with a clean rag soaked with Acetone for best results!

---

***If you do not have any of the specifications of your generator’s field, or if you don’t know where to start when trying to determine your field specs, please see the section below for instructions on measuring and calculating your field specifications.***

- Measure your exciter field resistance using a multimeter on your field leads. Record this value.
- Next, start and run the generator and apply 12V from a battery through your field leads and record the DC voltage produced by the generator Armature at A1 and A2. To determine your full load field voltage, use the following formula:

$$E_{Exc.} = \frac{E_{Gen.Conf.}}{\left( \frac{E_{Gen.Output}}{E_{Battery}} \right)} * 2$$

Where  $E_{Gen.Conf.}$  is your Generator’s configured voltage (e.g.: 125 or 250vdc),  $E_{Gen.Output}$  is your recorded output voltage, and  $E_{Battery}$  is your battery voltage (12V usually).

- Next, calculate your maximum field amperage using your measured field resistance and your calculated field voltage using the following formula:

$$I = \frac{E}{R}$$

Where  $I$  is your maximum field current,  $E$  is your calculated field voltage from the above formula, and  $R$  is your measured field resistance.

**Using the values you just measured and calculated, see the chart on the previous page to determine which rectifier module you should order with your DC250 DC Voltage Regulator.**



## Conversion From Older Shunt-Wound Voltage Regulation to Modern Solid-State Voltage Regulation

It is possible to use the DC250 DC Voltage Regulator with older Shunt-Wound generators that originally had manual or mechanical voltage regulators by converting the wiring as in the diagrams below. If the generator will not build up after conversion, try switching your F+ and F- leads at the regulator and try starting up again.

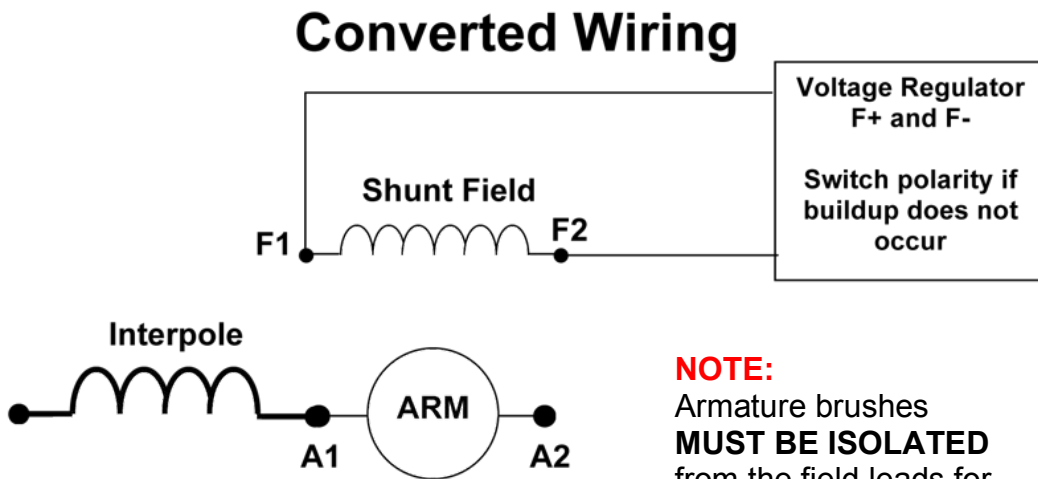
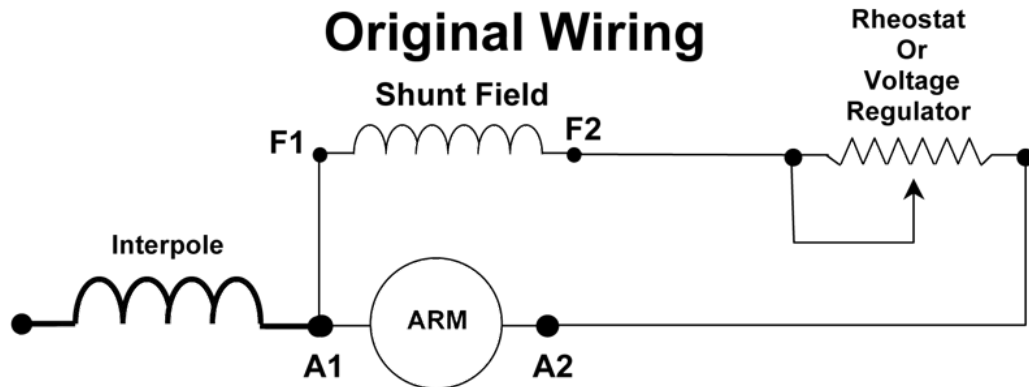

**NOTE:**  
Armature brushes  
**MUST BE ISOLATED**  
from the field leads for  
proper operation!



## Hookup Diagram

The DC250 DC Voltage Regulator controls the strength of the DC field of a DC generator to regulate the terminal voltage produced at A1 and A2 of the armature. The DC250 is capable of outputting 0-250vdc with an input of 250vdc.

Use the diagram shown below for proper hookup to the typical DC generator. **Note that the shunt field is isolated from the rest of the generator and connected ONLY to the DC250 DC Voltage Regulator!!** See Page 6 for details on how to convert the wiring on a typical Shunt-Field DC Generator for use with the DC250 DC Voltage Regulator! Before proceeding, verify that the Armature brushes are **ISOLATED** and connected **ONLY** to the DC250! Verify that the Shunt Field is **ISOLATED** and connected **ONLY** to the DC250 Voltage Regulator!

Note that the maximum input voltage to the DC250 DC Voltage Regulator is **250VDC!** **DO NOT input higher voltages into the DC250!** Severe damage to the unit will result!

**WARNING:**  
Fuse inputs to A+ and A- with 10/25/40adc\* 250V fast-blow fuses! Failure to properly fuse the DC250 Regulator can cause equipment failure or damage!!!

\*Fusing size corresponds to capacity of FM250 DC Rectifier module.

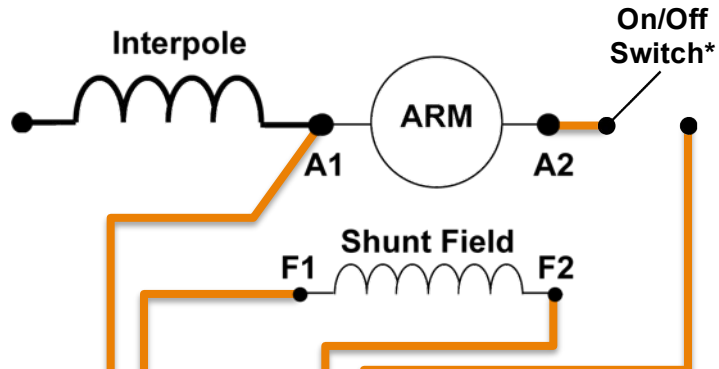

\* Switch **MUST** be rated 250VDC or higher with a current rating equal to or greater than the voltage regulator!!

**NOTE:** NEVER install a switch or breaker on the Field side of the voltage regulator! Only install a switch or disconnect on the Armature side of the regulator!

Remote Adjustment  
100KΩ @ 1/2W

**NOTE:**  
It is not necessary to jumper terminals 7 and 8 if not using the Remote Voltage Adjustment!

Internal Voltage Adjustment





## Initial Setup and Commissioning

1. Install the regulator and wire up to the hookup diagram.
2. Verify that the brushes and brush riggings are isolated, ungrounded, and connected ONLY to the DC250.
3. Turn the internal voltage control 15 or more turns counter clockwise (left) or until you hear the screw click. This procedure is necessary in case the original factory settings have been altered.

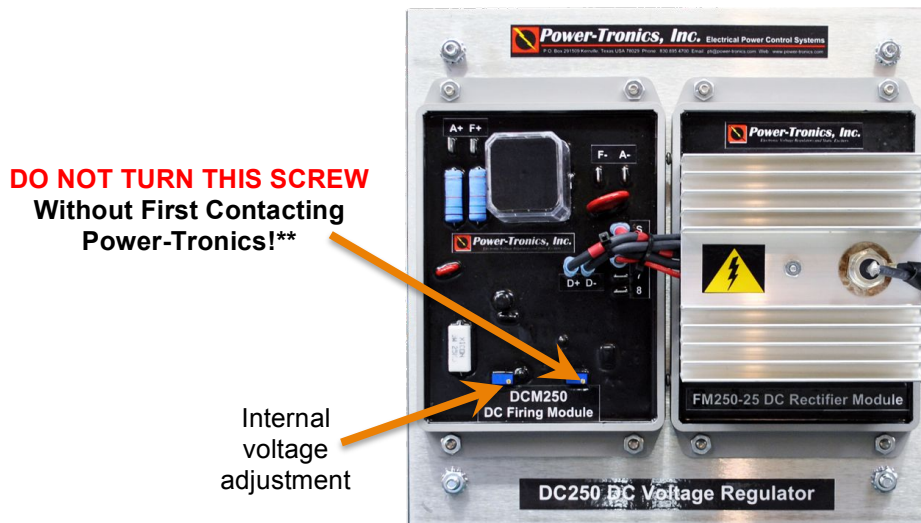

4. If you are using a remote voltage adjustment, set it at 50% of adjustment.
5. Start up the prime mover and bring up to operating speed and turn on the regulator switch (if used).
6. Set the internal voltage adjustment to the desired voltage setting for the generator output by turning the adjustment screw clockwise (right).  
**Note that the voltage adjustment is a 25-turn pot!**
7. Place the generator on line and observe the voltage.
8. Observe voltage regulation during no-load and full-load conditions. Once the voltage is set and regulating characteristics are satisfactory the installation procedure is complete.

**\*\* Special Note:** The DC250 DC Voltage Regulator is adjusted for a firing rate of 125pps and can be adjusted up to 1000pps if conditions require. **DO NOT** Adjust the firing rate screw without first contacting Power-Tronics for advisement!



## Optional Power-Tronics Add-On Modules

Power-Tronics offers optional add-on modules for the XR and DC series DC voltage regulators such as motor-operated potentiometers and digital interface cards. For more information on any of the modules below, visit our online catalog at:

[www.power-tronics.com](http://www.power-tronics.com)



### UIC200

#### Optical Interface Module

Allows the DC250 to be controlled externally by virtually any digital or computerized controller!

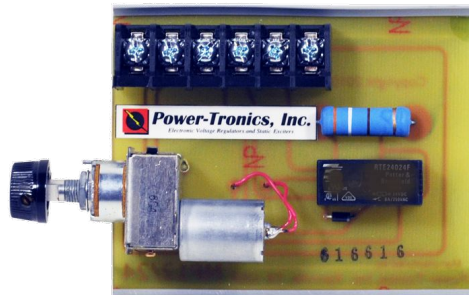

### MP12/MP24

#### Motorized Potentiometer

Allows the DC250 to be externally controlled by older automated controllers using pulsed signals or dry contacts for control!



## Application Troubleshooting

Installation of the DC250 DC Voltage Regulator is normally a very simple process; however occasionally conditions arise that require troubleshooting assistance. Because of the nature of DC voltage regulation, **please contact Power-Tronics for any troubleshooting assistance!**



## **Bench Check Procedures**

**Because of the nature of DC voltage regulation, the DC250 DC Voltage Regulator has no bench-test procedure. If you suspect a problem with your DC250, please contact Power-Tronics for assistance or service!**



## Installation Warranty Form

It is very important that you fill out this form completely when installing a voltage regulator. This form serves as a history record on the application. This form also contains the information needed by Power-Tronics, Inc., for repair and troubleshooting of any product you may be having problems with.

**Failure to fill out this form during installation will result in a cancellation of your warranty coverage! Filling out this form takes only minutes but will save hours or days later on if your product should require service!**

Product		Other options			
Serial Number					
Date of Installation					
Type of Generator				Model #	
	Brush type	[ ]			
	Brushless	[ ]			
AC Stator Information					
Wired for	Volts	Phase	Hz		
Generator Configuration: Lead					
Exciter/Rotor Information					
Exciter field resistance		$\Omega$		@	F+ / F- $\Omega$
Exciter field volts		vdc		@	Slip Rings $\Omega$
Description of problem with product or generator					
Your phone number			Name:		
Your fax number			Ship to Address:		
Your email address			Ship to City, State, Zip:		



## PRODUCT WARRANTY

**Power-Tronics, Inc.**, assumes no liability for damages due to incorrect voltage or other voltage related damages resulting from either output of the generator or input to the generator exciter system. These problems should be protected with external devices provided by the customer such as **fuses, surge suppressors, over/under voltage and frequency controls.**

**Power-Tronics, Inc.**, warranties **only parts and workmanship** of this product for a **period of 2 years from the original date of purchase from Power-Tronics, Inc.** Under warranty, Power-Tronics, Inc. will replace, exchange or repair the defective product **without labor or parts cost to the customer.** Remaining warranty of the original product will be transferred to the replaced or repaired product. To obtain warranty, a copy of the original Installation Warranty Form must be sent in with the defective product, which clearly shows the purchase date and serial number of the defective part. A repair request form must be sent in with the product before repairs will begin. You can obtain this form by contacting Power-Tronics, Inc.

**Send repairs to: Power-Tronics, Inc., 2802 Cobbler Ln., Kerrville Texas USA 78028.**

***Send in repairs only by UPS or FedEx.* USPS will NOT deliver to our facility!**

**Any one of the following conditions will void the warranty:**

- ❖ Overheating of the power supply resistor on the printed circuit card.
- ❖ Overheating of the MOSFET or freewheeling diode.
- ❖ Physical damage to the printed circuit card, housing or components.
- ❖ Unauthorized repair or alteration of printed circuit card.
- ❖ Installation by anyone other than a qualified professional generator service technician.
- ❖ Conductive or corrosive contamination of the circuit card.
- ❖ Removal of our company identification from the product.
- ❖ Removal of any conformal coating of the printed circuit card or components.
- ❖ Overheating of foil on the printed circuit card.
- ❖ Inappropriate or infeasible application.
- ❖ Use with any external device other than manufactured by Power-Tronics, Inc.
- ❖ Failure to fill out the attached warranty card during installation

**No other warranty is expressed or implied.**