



HVD1

High Voltage Disconnect Module

Most electrical generators do not have a means of preventing a disastrous over voltage condition from occurring that could destroy the generator and or the load that it is connected to.

The generator relies on a voltage regulator to control its voltage and *all* voltage regulators will eventually fail in one of three ways: No voltage, erratic voltage or the worst of all, high and uncontrollable voltage. Sometimes grounded exciter fields will cause high and uncontrolled voltage.

The **HVD1 High Voltage Disconnect Module** is specifically designed for protection from high voltage conditions on voltage regulated generators. It is universal and can be used with most brands and types of voltage regulators found in the industry today.

The HVD1 is installed in the incoming voltage supply of a voltage regulator and when the generator voltage exceeds a preset voltage set point, it instantaneously disconnects the power to the regulator, which causes the generator voltage to collapse. Once the HVD1 has been activated by high voltage, it can only be reset by pushing a mechanical pushbutton located on its disconnect relay.

This product is a very simple and affordable method of critical protection for prime power and standby generating systems.



Specifications

Input Voltage:	120, 208, or 240vac*
Trip Voltage:	139-143vac @ 120V Input 227-231vac @ 208V Input 259-263vac @ 240V Input
Frequency:	50-400Hz
Maximum Trip Amperage:	15aac @ 277vac
Trip Reset:	Manual / Mechanical
Physical Size:	3 x 4 x 2.5 in.
Weight:	12 oz
Fully Encapsulated:	Yes

* Input Voltage Must Be Specified at Time of Order!



Table of Contents

Introduction and Functional Description:.....	3
Determining Which Hookup Configuration to Use:.....	4
Separate Power Supply and Sensing:.....	5
Common Power Supply and Sensing:.....	6
Using the HVD1 with a Power-Tronics Static Exciter Module:.....	7
Using the HVD1 with a Power-Tronics Static Exciter:.....	8
Initial Setup and Commissioning:.....	9
Installation Warranty Form:.....	10
Product Warranty Certificate:.....	11



Introduction and Functional Description

Caution: Read This Installation Manual Carefully and Entirely!

Warning: Do not use digital equipment to read voltage, Hz, or amperage during this installation. Use only Analog sensing equipment! Failure to do so may result in damage to equipment or in personal injury!

ALWAYS perform all setup procedures off-line

ALWAYS wear eye protection

ALWAYS strip wire insulation properly or use insulated connectors

ALWAYS use analog metering equipment when setting up the regulator

ALWAYS ensure the HVD1 receives ample airflow

NEVER hold the HVD1 in your hand when energized

NEVER install the HVD1 in a place it can get wet or is exposed to the elements

NEVER mount the HVD1 over a screw, bolt, rivet, welding seam, or other fastener

NEVER insert a screwdriver or other object under the HVD1

NEVER install a switch in the DC portion of the regulator's wiring

NEVER touch any exposed part of the HVD1 while in operation

NEVER USE A DIGITAL FREQUENCY METER (It can give a false reading!)

Functional Description

The HVD1 High Voltage Disconnect Module is designed to help prevent runaway voltage conditions on electrical generators. Eventually, all electronic voltage regulators will fail in one of three ways: No voltage, erratic control, or high and uncontrollable voltage. The HVD1 prevents the latter from causing catastrophic damage to the generator or its connected load.

The HVD1 is truly a universal device, having been designed to operate with Power-Tronics or any other manufacturer's products! The HVD1 can be used with voltage regulators with common power and sensing leads, or with separate sensing leads as the installation requires.

The HVD1 is designed to trip roughly 20vac above the sensed voltage. Because of its unique circuitry, the HVD1 is able to tolerate a brief voltage spike caused by a large load rejection or a slow voltage regulator, but still trip the regulator offline should an actual fault occur!

A mechanical reset is employed on the HVD1 to force the user to investigate the cause of failure prior to resetting the device. Under normal operating circumstances, the HVD1 should never trip, thus if a trip has occurred, the cause should be determined!

The HVD1 contains no sensitive digital circuitry and is a completely passive approach to generator safety. Because of its rugged design, the HVD1 is designed to be reliable and operate for a lifetime.



Determining Which Hookup Configuration to Use

STOP! This manual *ONLY* covers installation of the HVD1 High Voltage Disconnect Module! If you are using an optional Power-Tronics Static Exciter Module or Static Exciter, refer to the instructions that came with your optional modules for their correct generator wiring hookup.

The HVD1 is configurable for 4 different modes of operation: **Common Sensing and Power Supply, Separate Sensing and Power Supply, Operating with a Power-Tronics Static Exciter Module, or Operating with a Power-Tronics Static Exciter.**

**YOU MUST CHOOSE THE CORRECT OPERATING MODE!!
CHOOSING THE INCORRECT OPERATING MODE CAN CAUSE A
DANGEROUS SITUATION WITH YOUR GENERATOR AND SEVERE
DAMAGE OR SAFETY HAZARDS CAN RESULT!!!**

To determine the proper connection for your generator and regulator you need to know which type of regulator you have and how it receives its power.

To determine the correct mode of operation for your installation, refer to the mode descriptions in the chart below:

- Your voltage regulator has separate power and sensing inputs. Your voltage regulator has a PMG, Harmonic Winding, or DPE Winding Input. Use **Separate Power and Sensing Mode (See Page 5)**
- Your voltage regulator has only a single power input with no separate sensing leads, no PMG, and no DPE or Harmonic Winding. (All Power-Tronics voltage regulators use this mode of operation) Use **Common Power and Sensing Mode (See Page 6)**
- You have a Power-Tronics voltage regulator and an SE350, SE450, SE900, or SEM100A Static Exciter Module. Use **Static Exciter Module Mode (See Page 7)**
- You have a Power-Tronics SE300, SE500, SE1500, SE2000, SE3000, SE6000, or a 3-Phase Power-Tronics Static Exciter. Use **Static Exciter Mode (See Page 8)**



Hookup Diagram For Voltage Regulators With Separate Power and Sensing Connections

(Use this Connection Mode if your voltage regulator utilizes separate power and sensing leads, such as a separate power input, Harmonic or DPE windings, or a PMG)

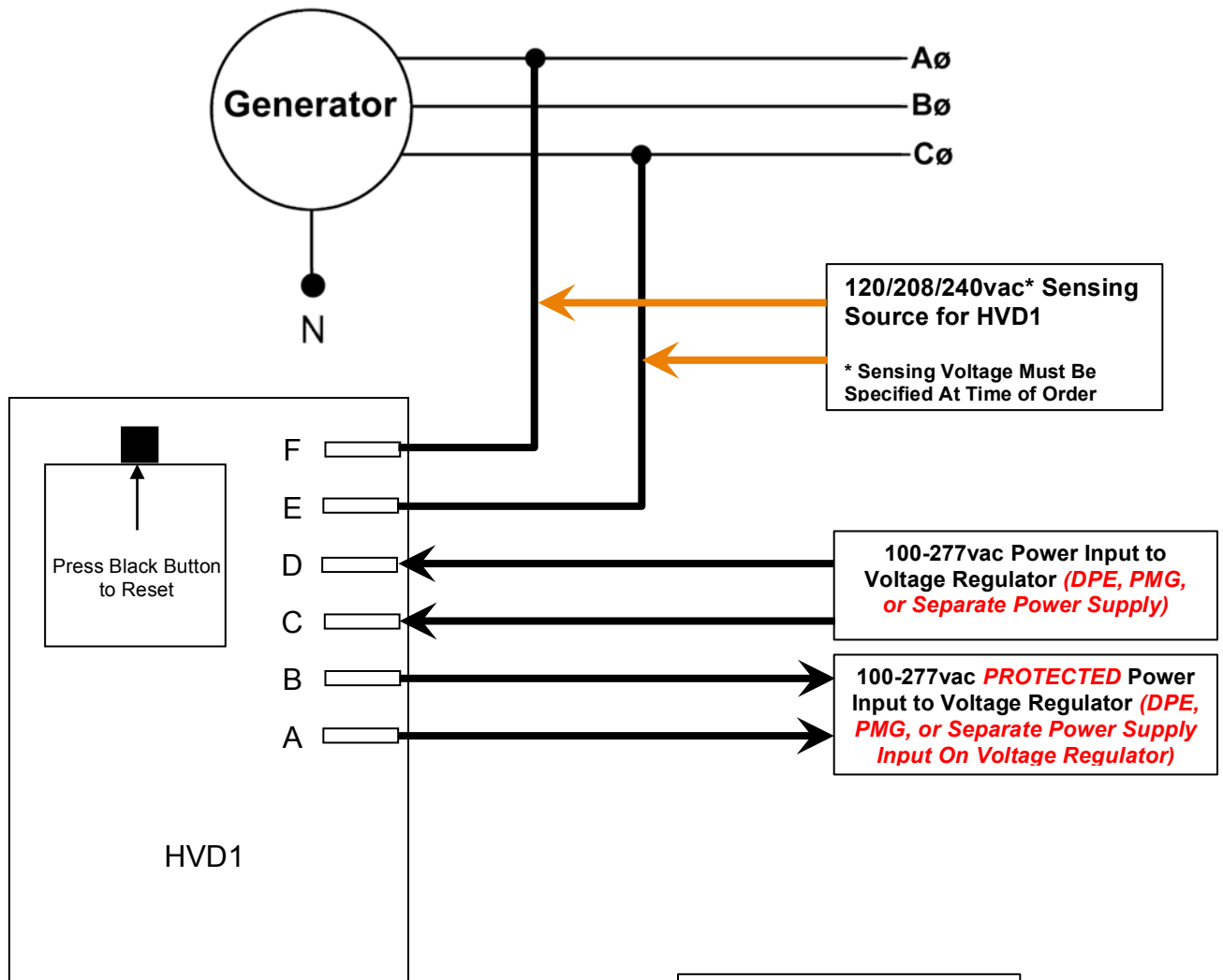

WARNING:
DO NOT FUSE INPUTS TO TERMINALS E AND F ON HVD1!!!

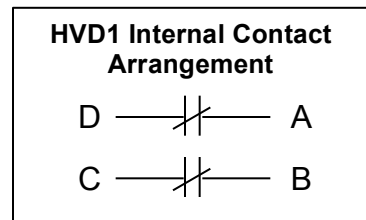



Hookup Diagram For Voltage Regulators With Common Power and Sensing Connections

(Use this Connection Mode if your voltage regulator utilizes the same input for both power and sensing. **ALL Power-Tronics Voltage Regulators use this connection method!**)

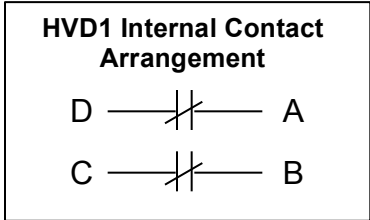
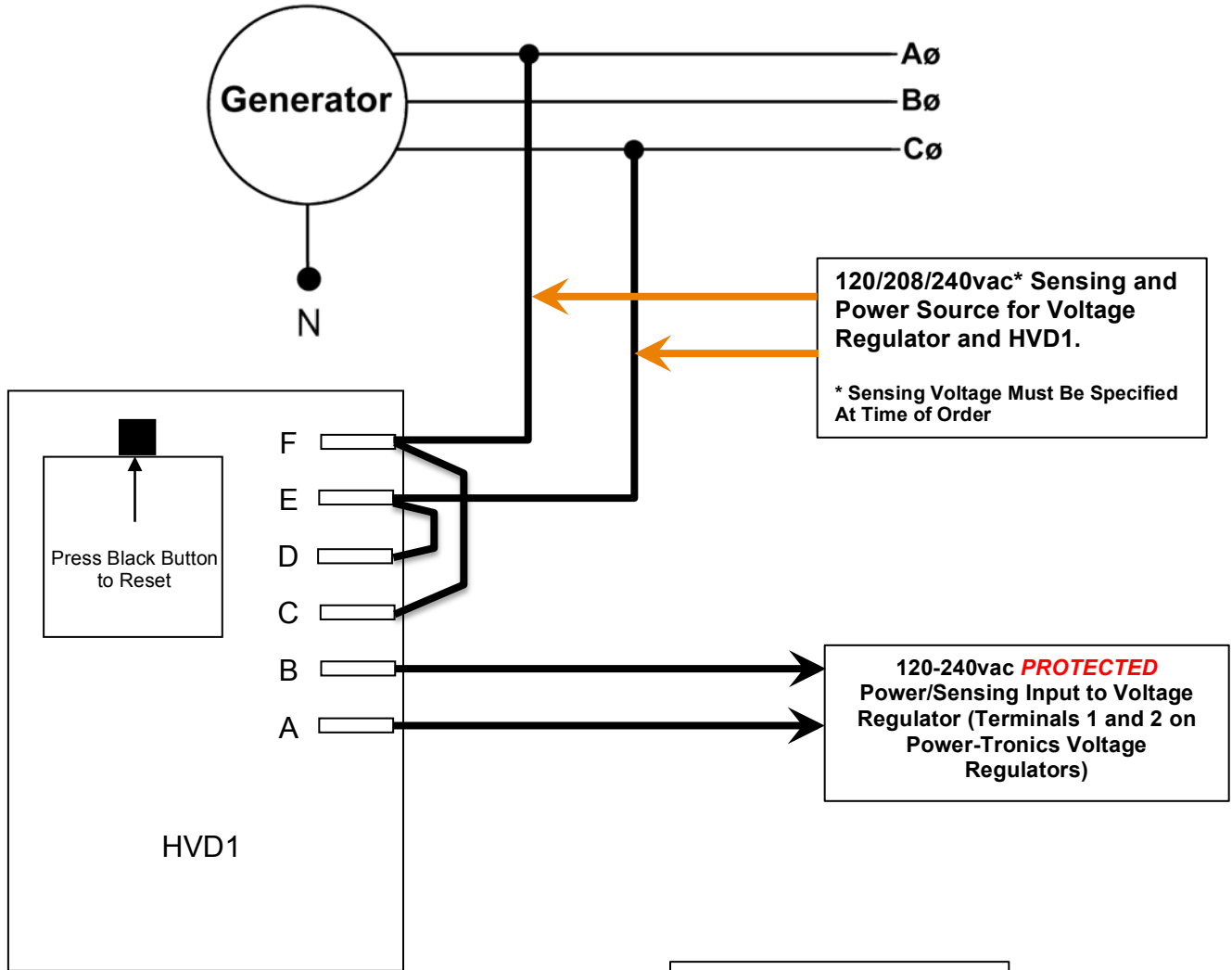

WARNING:
DO NOT FUSE INPUTS TO TERMINALS E AND F ON HVD1!!!



Hookup Diagram For Use With Power-Tronics Static Exciter Modules

(Use this Connection Mode if your installation uses a Power-Tronics SE350, SE450, SE900, or SEM100A Static Exciter Module)

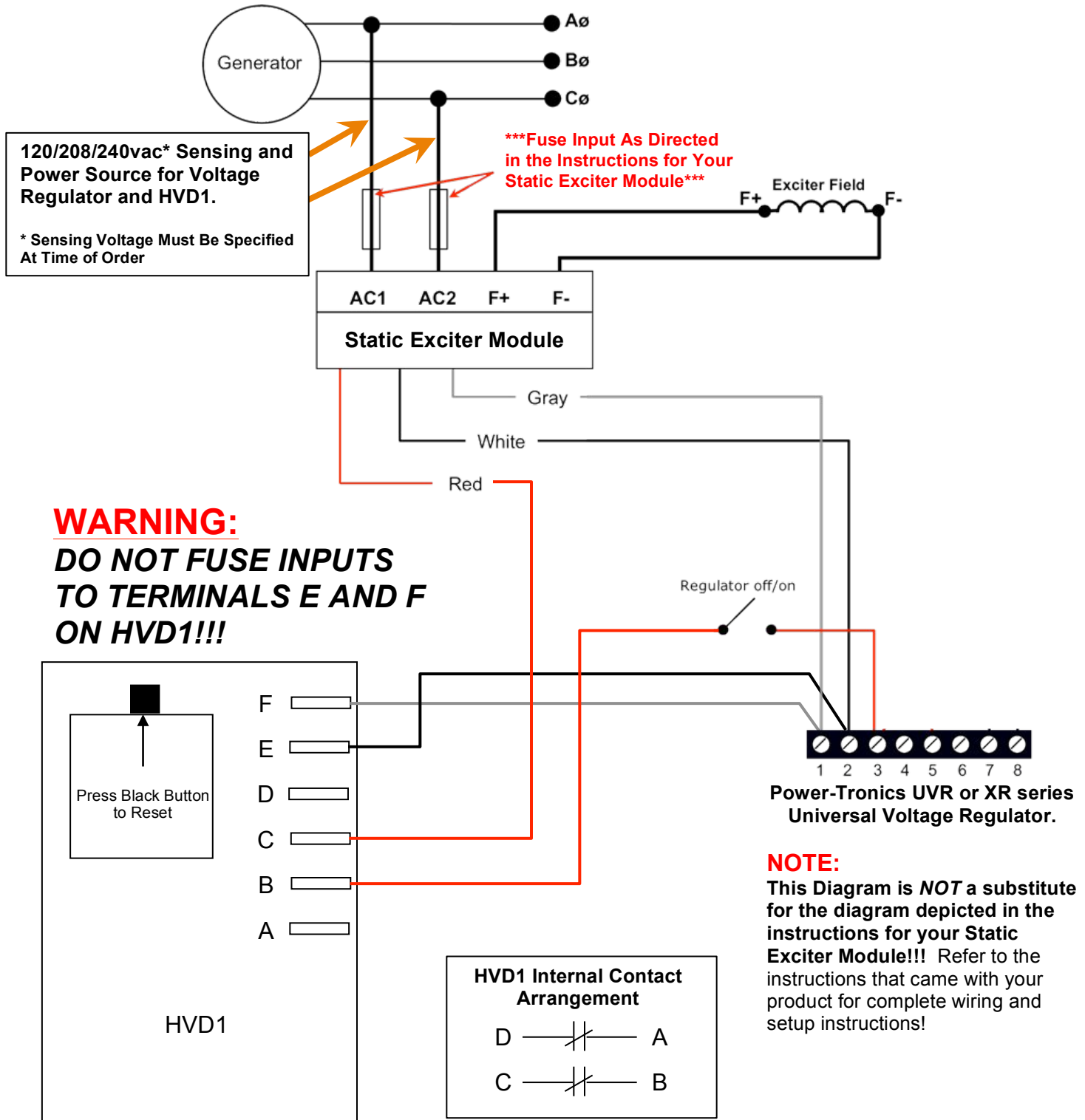



Hookup Diagram For Use With Power-Tronics Full Static Exciters

(Use this Connection Mode if your installation uses a Power-Tronics SE300, SE500, SE1500, SE2000, SE3000, or SE6000 Series Full Static Exciter. **NOTE:** Terminal Block shown in diagram below is genericized. "B", "BX", and "BF" models of Power-Tronics Static Exciters have additional X & Y terminals.)

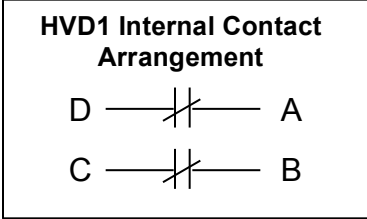
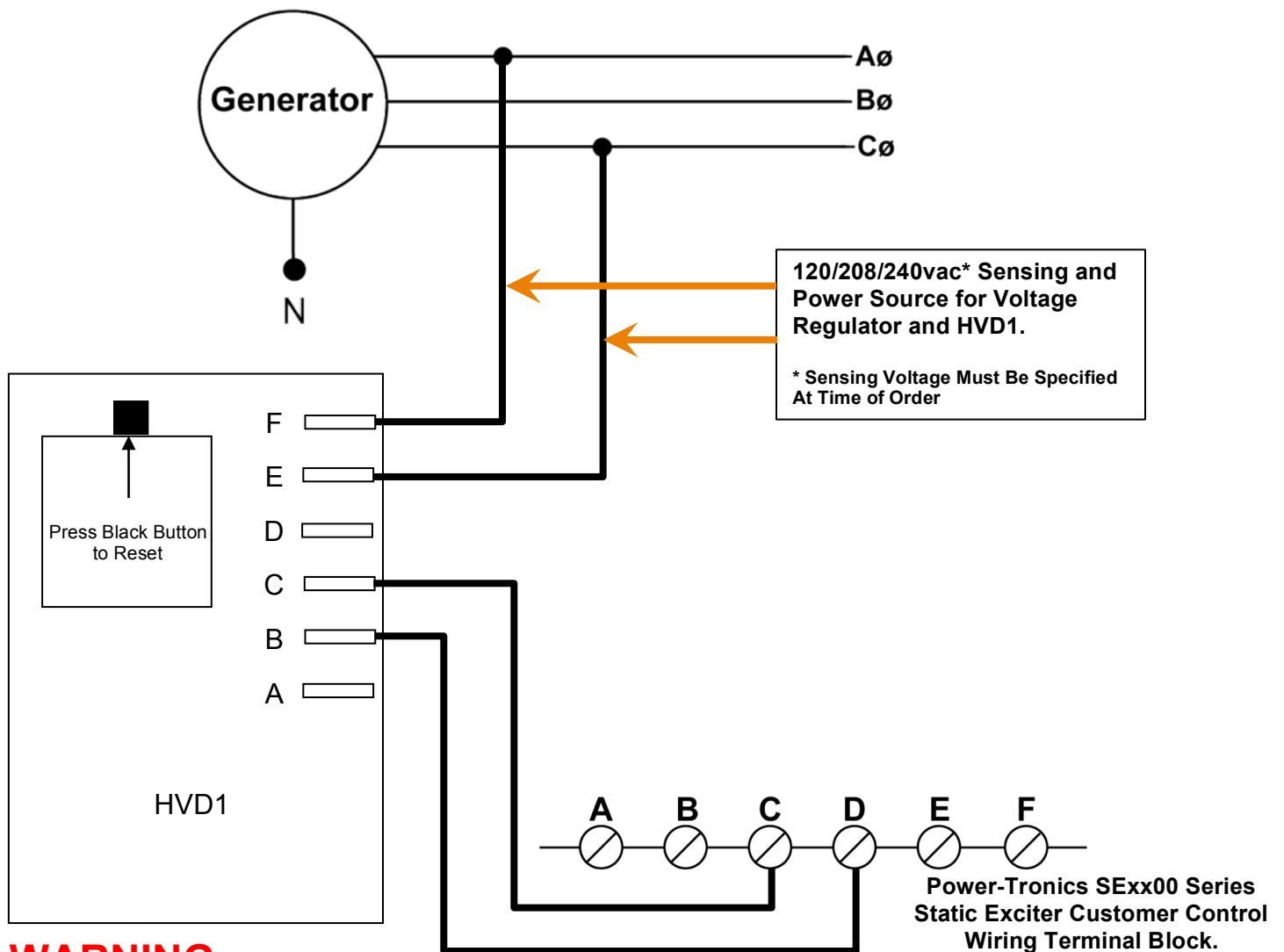



Initial Setup and Commissioning

1. Refer to your voltage regulator's instruction manual for initial setup and commissioning of the voltage regulator.
2. Wire up the HVD1 as shown in the appropriate diagram on pages 5-8.
3. Press the black reset button on the HVD1 to ensure the relay is reset. The HVD1 is shipped in a "tripped" position from Power-Tronics.
4. Commission the generator and regulator as outlined in your voltage regulator's instruction manual.
5. When satisfactory operation of the voltage regulator is achieved, installation and commissioning is complete.

Bench Test and Troubleshooting Information

The HVD1 High Voltage Disconnect Module is a safety device and therefore has no bench test procedures. If you suspect a problem or experience nuisance trips of the HVD1 during normal operation, please contact Power-Tronics immediately for assistance!

The HVD1 High Voltage Disconnect Module contains no user-serviceable parts and contains no user-adjustable adjustments.

Unauthorized adjustment or tampering of the HVD1 will result in a cancellation of your warranty and will release Power-Tronics from all liability!



Installation Warranty Form

It is very important that you fill out this form completely when installing a voltage regulator. This form serves as a history record on the application. This form also contains the information needed by Power-Tronics, Inc., for repair and troubleshooting of any product you may be having problems with.

Failure to fill out this form during installation will result in a cancellation of your warranty coverage! Filling out this form takes only minutes but will save hours or days later on if your product should require service!

Product		Other options			
Serial Number					
Date of Installation					
Type of Generator				Model #	
		Brush type	<input type="checkbox"/>		
		Brushless	<input type="checkbox"/>		
AC Stator Information					
Wired for	Volts	Phase	Hz		
Generator Configuration: Lead					
Exciter/Rotor Information					
Exciter field resistance		Ω		@ F+ / F-	Ω
Exciter field volts		vdc		@ Slip Rings	Ω
Description of problem with product or generator					
Your phone number			Name:		
Your fax number			Ship to Address:		
Your email address			Ship to City, State, Zip:		



PRODUCT WARRANTY

Power-Tronics, Inc., assumes no liability for damages due to incorrect voltage or other voltage related damages resulting from either output of the generator or input to the generator exciter system. These problems should be protected with external devices provided by the customer such as **fuses, surge suppressors, over/under voltage and frequency controls.**

Power-Tronics, Inc., warranties **only parts and workmanship** of this product for a **period of 2 years from the original date of purchase from Power-Tronics, Inc.** Under warranty, Power-Tronics, Inc. will replace, exchange or repair the defective product **without labor or parts cost to the customer.** Remaining warranty of the original product will be transferred to the replaced or repaired product. To obtain warranty, a copy of the original Installation Warranty Form must be sent in with the defective product, which clearly shows the purchase date and serial number of the defective part. A repair request form must be sent in with the product before repairs will begin. You can obtain this form by contacting Power-Tronics, Inc.

Send repairs to: Power-Tronics, Inc., 2802 Cobbler Ln., Kerrville Texas USA 78028.

***Send in repairs only by UPS or FedEx.* USPS will NOT deliver to our facility!**

Any one of the following conditions will void the warranty:

- ❖ Overheating of the power supply resistor on the printed circuit card.
- ❖ Overheating of the SCR or freewheeling diode.
- ❖ Physical damage to the printed circuit card, housing or components.
- ❖ Unauthorized repair or alteration of printed circuit card.
- ❖ Installation by anyone other than a qualified professional generator service technician.
- ❖ Conductive or corrosive contamination of the circuit card.
- ❖ Removal of our company identification from the product.
- ❖ Removal of any conformal coating of the printed circuit card or components.
- ❖ Overheating of foil on the printed circuit card.
- ❖ Inappropriate or infeasible application.
- ❖ Use with any external device other than manufactured by Power-Tronics, Inc.
- ❖ Failure to fill out the attached warranty card during installation

No other warranty is expressed or implied.