



PC1500BF

Phase control

The Power-Tronics PC1500BF Phase control is a self-contained complete Phase control. The PC1500BF Phase control is designed for continuous operation at up to 210vdc at 100adc!

The PC1500BF is uniquely designed to sit in a compact footprint while being passively convection cooled for a long service life. Because of its unique modular design, the PC1500BF minimizes downtime should a repair ever be necessary! The PC1500BF's compact design allows a wide variety of installation methods, including installations where space is at a premium.

The PC1500BF is a time-proven design, utilizing high-reliability components and a unique modular design to simplify repair. The PC1500BF is designed to provide a lifetime of service and is specifically built to minimize failures and potential downtime!

The PC1500BF is also capable of operation with Power-Tronics' wide variety of optional accessories, which allow the PC1500BF to be remotely operated by dry contact switching or by a PLC controller!

The PC1500BF Phase control is the latest upgrade to the PC1500B series of phase controls and replaces all previous Power-Tronics PC1500B and PC1500BX Phase controls!

Specifications

Input Voltage:	208 - 240vac
Frequency:	50 or 60 Hz
Control Range:	0-100%
Output Voltage:	0-210vdc @ 240vac input
Maximum Continuous Output:	100adc
Minimum Field Resistance:	2.1Ω @ 210vdc output
Physical Size:	10 x 20 x 8 in.
Weight:	18 lb.
Phase control:	PC500X
Repairable:	Yes
Internal Protection:	Fuses, cartridge type
External Voltage Adjustment:	Yes
System Operating Indicator:	Yes
Optional External Controls	Yes



Table of Contents

Introduction and Functional Description:.....	3
Determining Application Sizing:.....	4
Connection Diagram:.....	6
Initial Setup and Commissioning:.....	7
Optional Power-Tronics Add-On Modules:.....	8
Bench Check Procedures:.....	9
Installation Warranty Form:.....	10
Product Warranty Certificate:.....	11



Introduction and Functional Description

Caution: Read This Installation Manual Carefully and Entirely!

Warning: Do not use digital equipment to read voltage, Hz, or amperage during this installation. Use only Analog sensing equipment! Failure to do so may result in damage to equipment or in personal injury!

ALWAYS perform all setup procedures off-line

ALWAYS wear eye protection

ALWAYS strip wire insulation properly or use insulated connectors

ALWAYS use analog metering equipment when setting up the phase control

ALWAYS ensure the phase control receives ample airflow

ALWAYS use adequate fusing

NEVER hold the phase control in your hand or lap when energized

NEVER install the phase control in a place it can get wet or is exposed to the elements

NEVER mount the phase control over a screw, bolt, rivet, seam, or other fastener

NEVER remove the PC500X cover while the unit is in operation

NEVER insert a screwdriver or other object under the regulator cover

NEVER touch any exposed part of the PC1500BF during operation (**LIVE HEATSINKS**)

NEVER install a switch in the DC portion of the phase control's wiring

NEVER USE A DIGITAL FREQUENCY METER (It can give a false reading!)

Functional Description

The PC1500BF Phase Control is the result of over 20 years of engineering efforts and offers high-demand features at a competitive price point. The PC1500BF is a proven design and is engineered to greatly simplify setup while offering extreme reliability. When properly installed, the PC1500BF Phase Control is designed to provide a lifetime of service.

An automatic phase control has several automated tasks it must perform in order to provide reliable, clean, and regulated electricity. It must maintain a preset setpoint and protect both itself and the connected load should a fault situation arise.

The PC1500BF uses field-replaceable cartridge fuses to protect its internal circuitry should a fault occur and the load current exceeds what the phase control is capable of delivering. It also contains reliable circuitry that is designed to maintain a setpoint regardless of outside influences or ambient temperature.

Due to its extreme simplicity, the PC1500BF Phase Control is uncommonly reliable and offers features and accuracy usually only offered by much more complicated and often much more expensive phase controls.



Determining Correct Application Sizing

The PC1500BF Phase control is designed for use with 208-240VAC input. It contains internal suppression for use with brush-type loads such as synchronous motors. Before installation, it is necessary to verify that the PC1500BF is the correct product for your application.

To determine if the PC1500BF is the correct product for your load you need to know any two of the following 3 specifications from the rating plate of your load:

- 1: Control Field Voltage (in DC Volts) [Generally given in full load Voltage on nameplates]
- 2: Control Field Resistance (in Ohms) **[See Note Below]**
- 3: Connected Load Amperage (in DC Amps) [Generally given in full load Amps on nameplates]

Using the specifications obtained from your connected load, verify that your load fits the specifications from the chart or graph below:

- Connected load full load voltage is 125VDC or less, and your control field resistance is 2.1Ω or greater.

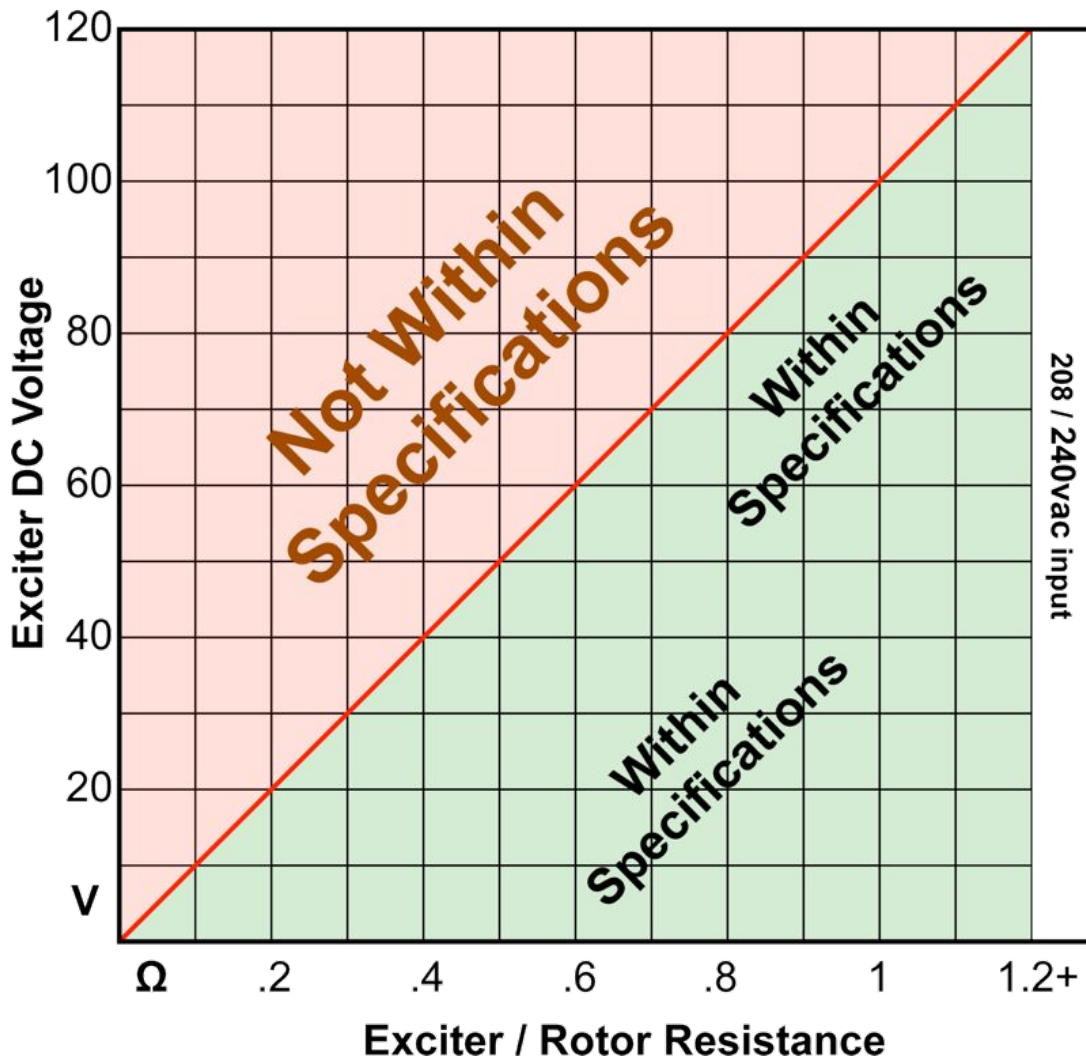



Note about Field Resistance

When measuring field resistance on a brush-type device, such as a synchronous motor, measure the resistance through both the field leads as well as directly on the slip rings themselves.

The readings you obtain should ideally be the same, but *no more than 1% difference.*

If you show more than 1% difference in reading your device has brush and ring contact problems and will need cleaning or maintenance before installing the PC1500BF.

Failure to correct brush and ring contact problems will result in severe damage to the phase control as well as possible PERMANENT damage to the slip rings themselves!

NEVER use emery cloth, carborundum stones, “comm sticks”, or Tuner cleaner to dress or clean slip rings!

They will make a bad problem much, much worse! Only use Garnet or Flint sandpaper and clean with a clean rag soaked with Acetone for best results!



Connection Diagram

WARNING: The PC1500BF Phase Control is NOT Suitable for use on Electrical Generators!!!

The PC1500BF is a Full-Wave rectified phase control, which allows a maximum of 210VDC at 100 ADC continuous with an input voltage of 240VAC.

This product is typically used on slip-ring synchronous motors or on inductive loads with full load control field voltages of 125VDC or less and full load exciter field amperages between 30 and 90ADC.

Note that the maximum input voltage to the PC1500BF Phase control is 240VAC! DO NOT input 277VAC into the PC1500BF! Severe damage to the unit will result! For use on 480V or higher systems, connect the PC1500BF to an appropriate step-down transformer to supply 240VAC to the PC1500BF.

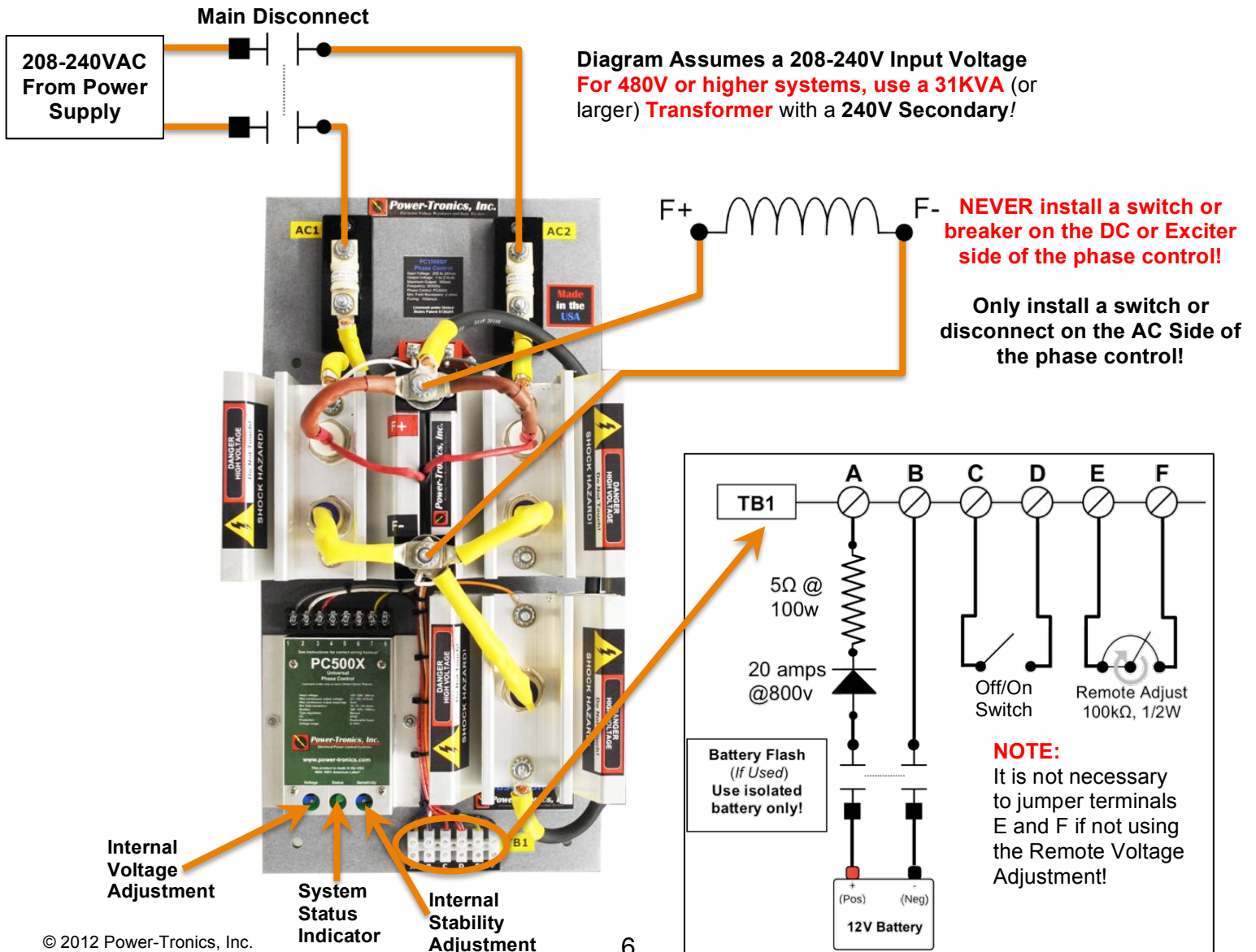



Initial Setup and Commissioning

1. Install the PC1500BF and wire up according to the wiring diagram on page 6.
2. If installing the PC1500BF on a load containing slip rings and brushes, verify that the brushes and brush riggings are isolated, ungrounded, and connected ONLY to the PC1500BF.
3. Turn the internal voltage control (Shown on page 6 and below with cover of PC500X removed for clarity) 15 or more turns counter clockwise (left) or until you hear the screw click. This procedure is necessary in case the original factory settings have been altered.

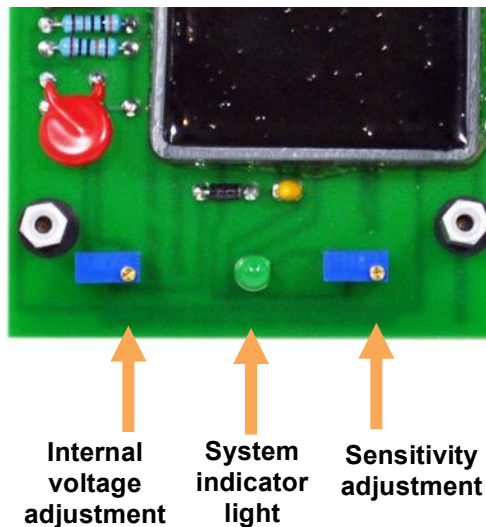

4. If you are using a remote voltage adjustment, set it at 50% of adjustment.
5. If you are using the PC1500BF on a synchronous motor, bring the motor up to operating speed and turn on the phase control switch (if used).
6. Set the internal voltage adjustment to the desired voltage setting for the connected load by turning the adjustment screw clockwise (right).
Note that the voltage adjustment is a 25-turn pot!
7. Check remote adjustment range (if used) for satisfactory sensitivity. If the adjustment range is too sensitive, slowly turn the Stability adjustment clockwise until a satisfactory adjustment range is achieved. **NOTE: You may need to adjust your Voltage adjustment during this process!**
8. Observe operation during no-load and full-load conditions. Once the voltage is set and adjustment characteristics are satisfactory the installation procedure is complete.



Optional Power-Tronics Add-On Modules

Power-Tronics offers a wide array of optional add-on modules for the PC1500BF Phase control. For more information on any of the modules below, visit our online catalog at:

www.power-tronics.com

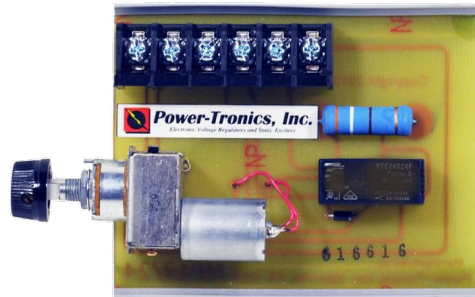

MP12/MP24

Motorized Potentiometer

Allows the PC1500BF to be externally controlled by older automated controllers using pulsed signals or dry contacts for control!



UIC200

Optical Interface

Allows the PC1500BF to be controlled externally by virtually any digital load-sharing controller, VAR controller, genset controller, or digital governor controller!



Bench Check Procedures

1. Wire up the PC1500BF as shown in the figure below.
2. Connect up two 120 volt 50 to 150 watt light bulbs in series to the F+ and F- Terminals.
3. Install a temporary jumper wire between terminals C and D on TB1 Terminal Board.
4. Turn the internal voltage adjustment on the PC1500BF Phase Control fully Counter-Clockwise (Left) before beginning the testing procedures below.
5. Input 208-240VAC fused at no more than 5A into the PC1500BF. **The test light should be OFF.**
6. Slowly turn the internal voltage adjustment on the PC1500BF Phase Control Clockwise (Right) until the lights glow. **The test light should light to FULL Brightness. NOTE: It may take several turns of the adjustment screw before the lights illuminate!**
7. Slowly turn the internal voltage adjustment of the PC1500BF Phase Control Counter-Clockwise (Left) until the lights go dark. **The test light should be OFF. NOTE: It may take several turns of the adjustment screw before the lights go dark!**
8. Turn off power and disconnect the PC1500BF from your power source. Inspect all electronic components on the PC1500BF to ensure they are isolated from touching any part of the PC1500BF housing.
9. **If you were able to successfully perform all of these tests, the PC1500BF is good.**

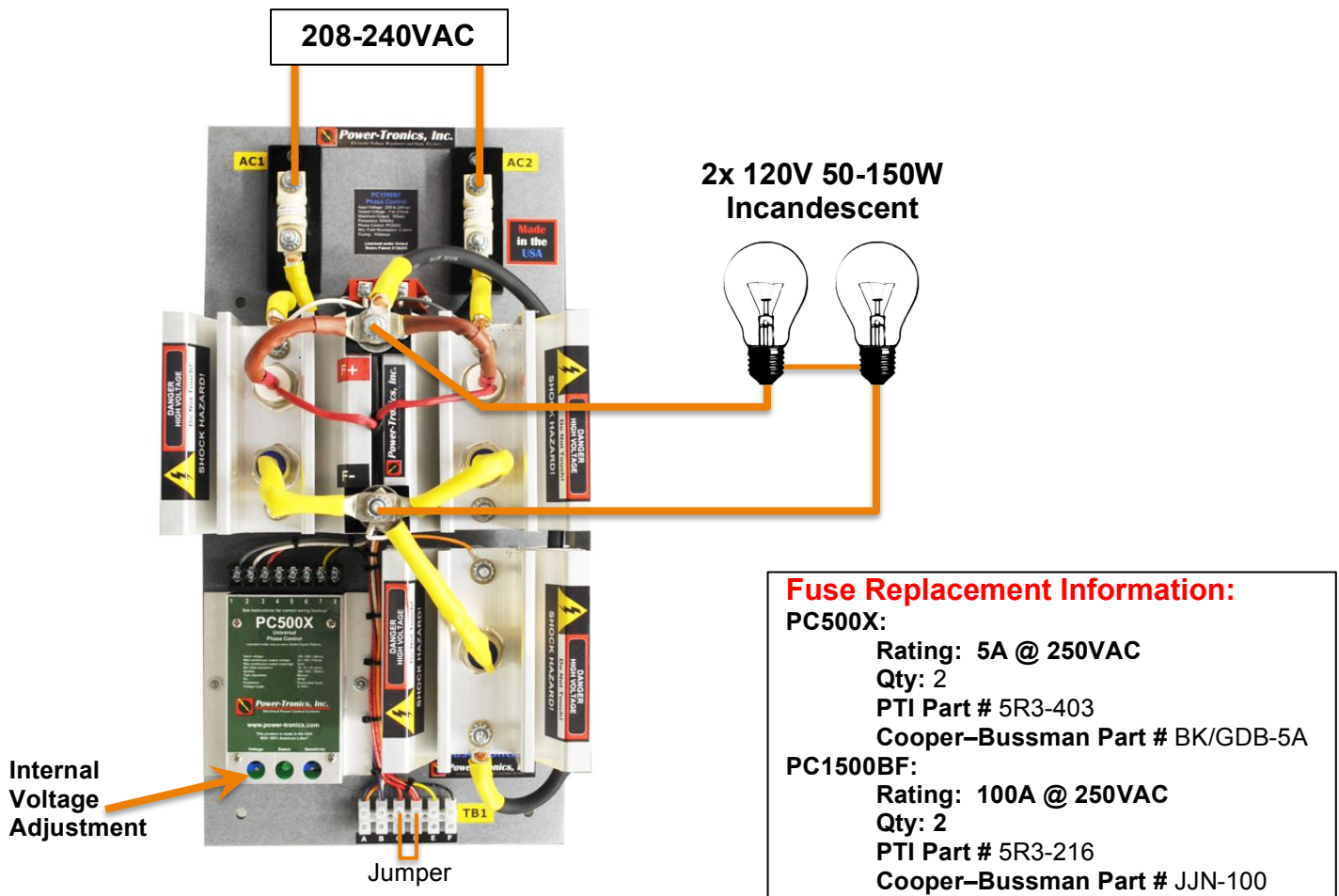



Installation Warranty Form

It is very important that you fill out this form completely when installing a phase control. This form serves as a history record on the application. This form also contains the information needed by Power-Tronics, Inc., for repair and troubleshooting of any product you may be having problems with.

Failure to fill out this form during installation will result in a cancellation of your warranty coverage! Filling out this form takes only minutes but will save hours or days later on if your product should require service!

Product		Other options		
Serial Number				
Date of Installation				
Type of Generator			Model #	
	Brush type	<input type="checkbox"/>		
	Brushless	<input type="checkbox"/>		
AC Stator Information				
Wired for	Volts	Phase	Hz	
Generator Configuration: Lead				
Exciter/Rotor Information				
Exciter field resistance		Ω		@ F+ / F- Ω
Exciter field volts		vdc		@ Slip Rings Ω
Description of problem with product or generator				
Your phone number		Name:		
Your fax number		Ship to Address:		
Your email address		Ship to City, State, Zip:		



PRODUCT WARRANTY

Power-Tronics, Inc., assumes no liability for damages due to incorrect voltage or other voltage related damages resulting from either output of the generator or input to the generator exciter system. These problems should be protected with external devices provided by the customer such as **fuses, surge suppressors, over/under voltage and frequency controls.**

Power-Tronics, Inc., warranties **only parts and workmanship** of this product for a **period of 2 years from the original date of purchase from Power-Tronics, Inc.** Under warranty, Power-Tronics, Inc. will replace, exchange or repair the defective product **without labor or parts cost to the customer.** Remaining warranty of the original product will be transferred to the replaced or repaired product. To obtain warranty, a copy of the original Installation Warranty Form must be sent in with the defective product, which clearly shows the purchase date and serial number of the defective part. A repair request form must be sent in with the product before repairs will begin. You can obtain this form by contacting Power-Tronics, Inc.

Send repairs to: Power-Tronics, Inc., 2802 Cobbler Ln., Kerrville Texas USA 78028.

***Send in repairs only by UPS or FedEx.* USPS will NOT deliver to our facility!**

Any one of the following conditions will void the warranty:

- ❖ Overheating of the power supply resistor on the printed circuit card.
- ❖ Overheating of the SCR or freewheeling diode.
- ❖ Physical damage to the printed circuit card, housing or components.
- ❖ Unauthorized repair or alteration of printed circuit card.
- ❖ Installation by anyone other than a qualified professional generator service technician.
- ❖ Conductive or corrosive contamination of the circuit card.
- ❖ Removal of our company identification from the product.
- ❖ Removal of any conformal coating of the printed circuit card or components.
- ❖ Overheating of foil on the printed circuit card.
- ❖ Inappropriate or infeasible application.
- ❖ Use with any external device other than manufactured by Power-Tronics, Inc.
- ❖ Failure to fill out the attached warranty card during installation

No other warranty is expressed or implied.