



SE450

Static Exciter Module



The Power-Tronics SE450 Static Exciter Module is a self-contained external rectifier assembly for all Power-Tronics XR and UVR series voltage regulators. The SE450 Static Exciter Module allows a standard Power-Tronics voltage regulator to control exciter fields with current requirements up to 25 amps DC at 210VDC!

The SE450 is a unique design, intended to sit on top of the voltage regulator to simplify installation and reduce installation space. Because of its unique modular design, it reduces the need to stock special voltage regulators for higher current exciter fields, reducing the amount of products needed to be kept in stock and vastly simplifying voltage regulator replacement!

The SE450 is a very robust design and is intended to operate for a lifetime. However, should repair ever be necessary, the SE450 is extremely simple to repair, minimizing downtime!

The SE450 is also capable of operating in a tandem condition with 2 SE450 modules connected to a single voltage regulator for exciter fields requiring up to 50 amps DC at 210VDC continuous!

The SE450 Static Exciter is compatible with all Power-Tronics UVR, XR, and certain older VR series voltage regulators, as well as the Power-Tronics PC500X, UVR500PC, and XR500PC phase controllers!

Specifications

Input Voltage:	120 / 208 or 240vac
Frequency:	N/A
Output Voltage:	0-105vdc @ 120vac input 0-210vdc @ 240vac input
Maximum Continuous Output:	25adc
Maximum Forcing Output:	30adc
Minimum Field Resistance:	4.2Ω @ 105vdc output 8.4Ω @ 210vdc output
Physical Size:	3.25 x 3.50 x 4.75 in.
Weight:	10 oz
Repairable:	Yes



Table of Contents

Introduction and Functional Description:.....	3
Determining Which Hookup Configuration to Use:.....	4
Hookup Connection A:.....	6
Hookup Connection B:.....	7
Hookup Connection C:.....	8
Hookup Connection D:.....	9
Initial Setup and Commissioning:.....	10
Parallel Configuration for Connection A & B:.....	11
Parallel Configuration for Connection C & D:.....	12
Optional Power-Tronics Add-On Modules:.....	13
Application Troubleshooting:.....	14
Bench Check Procedures:.....	15
Installation Warranty Form:.....	16
Product Warranty Certificate:.....	17



Introduction and Functional Description

Caution: Read This Installation Manual Carefully and Entirely!

Warning: Do not use digital equipment to read voltage, Hz, or amperage during this installation. Use only Analog sensing equipment! Failure to do so may result in damage to equipment or in personal injury!

ALWAYS perform all setup procedures off-line

ALWAYS wear eye protection

ALWAYS strip wire insulation properly or use insulated connectors

ALWAYS use analog metering equipment when setting up the regulator

ALWAYS ensure the regulator receives ample airflow

ALWAYS use adequate fusing

NEVER hold the regulator in your hand when energized

NEVER install the regulator in a place it can get wet or is exposed to the elements

NEVER mount the regulator over a screw, bolt, rivet, welding seam, or other fastener

NEVER remove the regulator cover while the unit is in operation

NEVER insert a screwdriver or other object under the regulator or SE450 cover

NEVER touch any exposed part of the SE450 during operation

NEVER install a switch in the DC portion of the regulator's wiring

NEVER USE A DIGITAL FREQUENCY METER (It can give a false reading!)

Functional Description

The SE450 Static Exciter Module has a proven track record of over 20 years of extreme reliability and robustness. It offers an inexpensive and unique way to upgrade a standard voltage regulator to a miniature static exciter with a minimum of connections and a minimum of installation space.

The SE450 is designed to work with Power-Tronics UVR and XR series voltage regulators and UVR, XR, and PC series phase controllers. Coupled with one of these products, the SE450 allows field excitation of 105VDC at 25ADC for a single unit, or 105VDC at 50ADC for tandem units.

Regulation accuracy depends on the voltage regulator the SE450 is used with. If used with the XR500D series Universal Voltage Regulator, the voltage regulation will be within +/- .25%. Other voltage regulators will regulate within their printed specifications.

**The SE450 does not contain internal fusing and must be fused externally.
Always use 25A 250VAC fast-blow fuses with the SE450 Static Exciter Module!**



Determining Which Hookup Configuration to Use

STOP! DO NOT use the instruction manual that came with your voltage regulator when using the SE450 Static Exciter Module! Use this manual instead! It contains the most up to date information available regarding your product!

The SE450 Static Exciter Module is capable of being connected several different ways to accommodate a wide variety of generator exciter configurations. It is necessary to choose the proper mode of operation for your generator in order to get the best regulation and fastest response time possible.

To determine the proper connection for your generator you need to know any two of the following 3 specifications from the rating plate of your generator:

- 1: Exciter Field Voltage (in DC Volts) [Generally given in full load Voltage on nameplates]
- 2: Exciter Field Resistance (in Ohms) **[See Note Below]**
- 3: Exciter Field Amperage (in DC Amps) [Generally given in full load Amps on nameplates]

Using the specifications obtained from your generator exciter, select a Connection (A, B, C, or D) from the chart or graph below:

- Exciter field resistance is more than 8.4 ohms and exciter full load voltage is rated at 125vdc or less. **Use connection A (See Page 6)**
- Exciter field resistance is more than 4.2 ohms, but less than 8.4 ohms and exciter full load voltage is rated at 125vdc or less. **Use connection B (See Page 7)**
- Exciter field resistance is more than 4.2 ohms and exciter full load voltage is rated at 63vdc or less. **Use connection C (See Page 8) This is a very rare configuration and should be used with the SE350 Static Exciter Module if possible for best regulation results!**
- Exciter field resistance is more than 2.1 ohms, but less than 4.2 and exciter full load voltage is rated at 63vdc or less. **Use connection D (See Page 9) This is a very rare configuration and should be used with SE350 Static Exciter Modules if possible for best regulation results!**

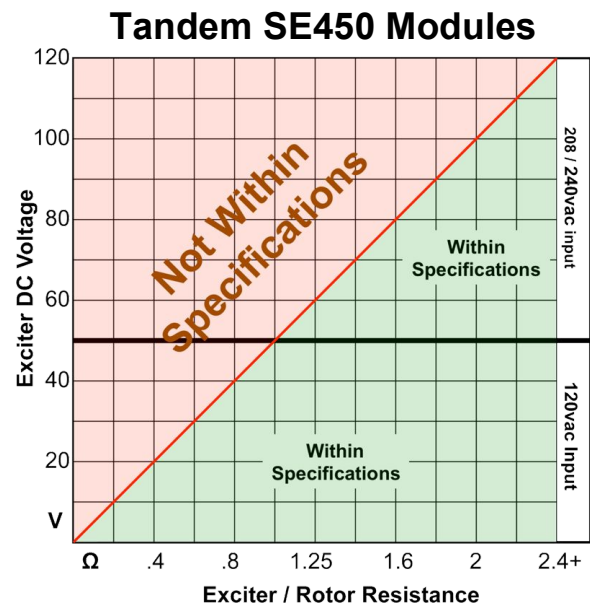
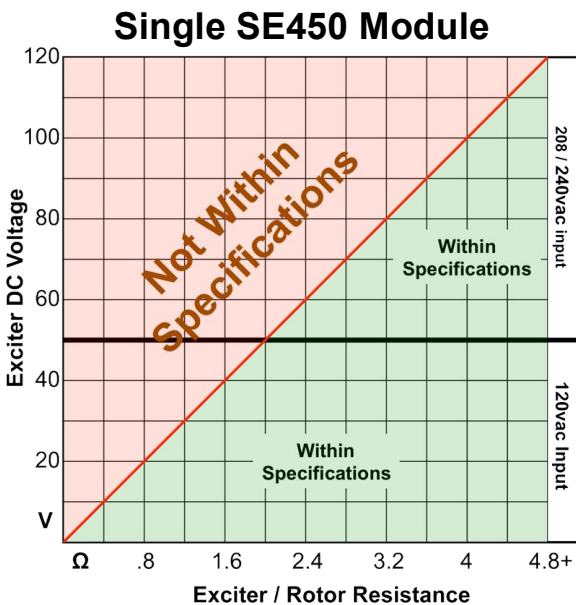



Note about Field Resistance:

- When measuring field resistance on a brushless generator, simply measure the resistance of the exciter field through your field leads with a multimeter.
- When measuring field resistance on a brush-type generator, measure the resistance through both the field leads as well as directly on the slip rings themselves. **The readings you obtain should ideally be the same, but no more than 1% difference.** If you show more than 1% difference in reading your generator has brush and ring contact problems and will need cleaning or maintenance before installing the SE450. **Failure to correct brush and ring contact problems will result in severe damage to the voltage regulator as well as possible PERMANENT damage to the slip rings themselves!** NEVER use emery cloth, carborundum stones, “comm sticks”, or Tuner cleaner to dress or clean slip rings. They will make a bad problem much, much worse! Only use Garnet or Flint sandpaper and clean with a clean rag soaked with Acetone for best results!

If you do not have any of the specifications of your generator’s exciter, or if you don’t know where to start when trying to determine your exciter specs, please see the section below for instructions on measuring and calculating your exciter specifications.

- Measure your exciter field resistance using a multimeter on your field leads. Record this value. If you have a brush-type generator, also take a resistance reading on your slip rings: the value you obtain on the slip rings should be no more than 1% difference from the value you obtained through the field leads.
- Next, start and run the generator and apply 12V from a battery through your field leads and record the AC voltage produced by the generator. To determine your full load exciter field voltage, use the following formula:

$$E_{Exc.} = \frac{E_{Gen.Conf.}}{\left(\frac{E_{Gen.Output}}{E_{Battery}} \right)} * 2$$

Where $E_{Gen.Conf.}$ is your Generator’s configured voltage (e.g.: 120, 208, 240, 480V, etc.), $E_{Gen.Output}$ is your recorded output voltage, and $E_{Battery}$ is your battery voltage (12V usually).

- Next, calculate your maximum exciter field amperage using your measured field resistance and your calculated exciter voltage using the following formula:

$$I = \frac{E}{R}$$

Where I is your maximum exciter field current, E is your calculated field voltage from the above formula, and R is your measured field resistance.

Using the values you just measured and calculated, see the chart on the previous page to determine which connection you should use to connect the SE450 to your generator.



Connection A

(See page 11 if the generator will be paralleled using this connection)

Connection A is a Full-Wave rectified configuration, which allows a maximum of 210VDC at 25 ADC continuous with an input voltage of 240VAC.

This connection is typically used on brushless and slip-ring generators with full load field voltages less than 125VDC and full load exciter field amperages between 5 and 25ADC.

Note that the maximum input voltage to the SE450 Static Exciter Module is 240VAC! DO NOT input 277VAC into the SE450! Severe damage to the unit will result! For use on 480V systems, either connect the SE450 to the winding center taps T7 and T8 or use a 480-240V step-down transformer.

Connecting the input of the SE450 to 2 different legs of the generator as shown in the diagram below will result in greater regulation accuracy than when connecting line-neutral.

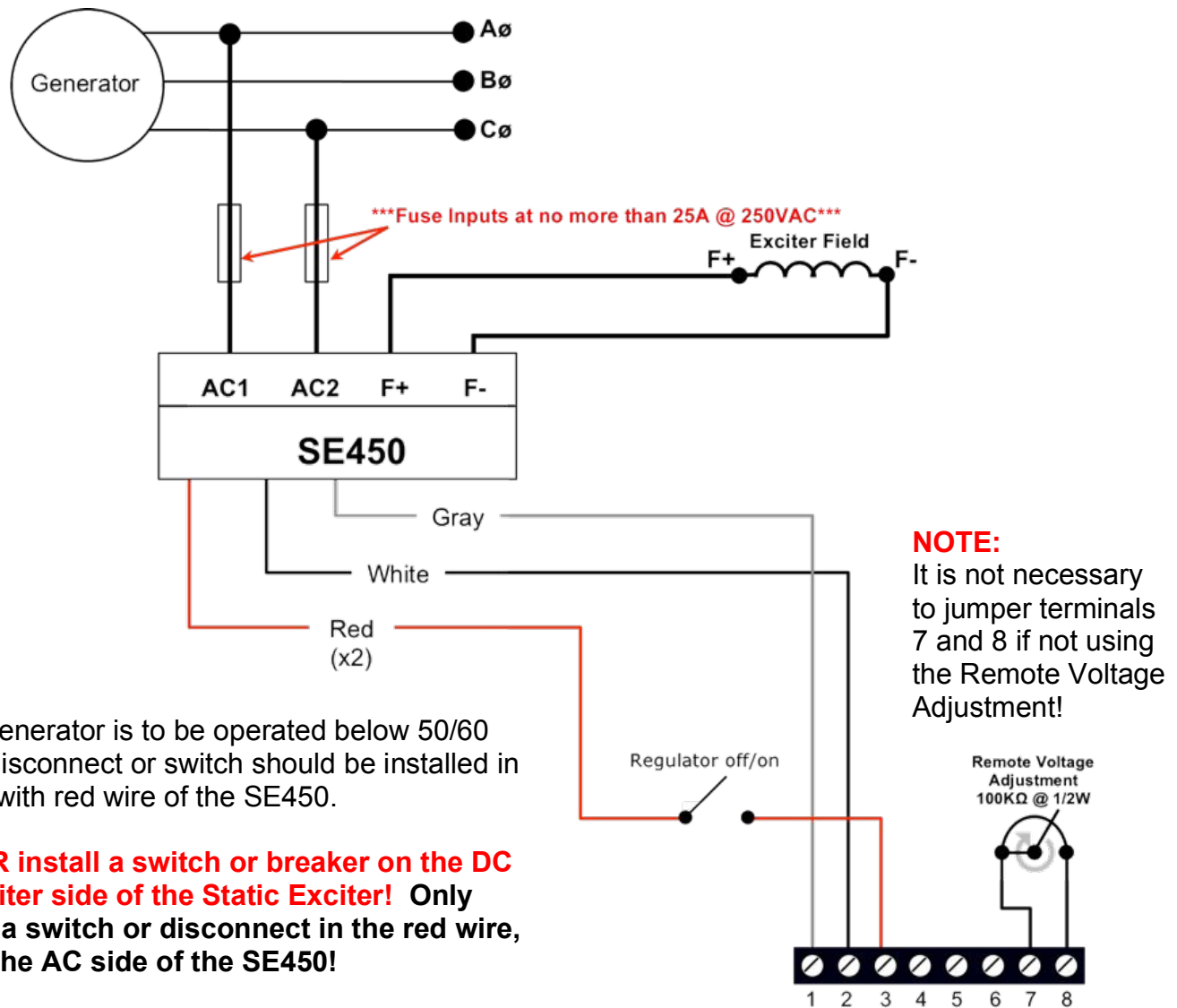

NOTE:

If the generator is to be operated below 50/60 Hz, a disconnect or switch should be installed in series with red wire of the SE450.

NEVER install a switch or breaker on the DC or Exciter side of the Static Exciter! Only install a switch or disconnect in the red wire, or on the AC side of the SE450!



Connection B

(See page 11 if the generator will be paralleled using this connection)

Connection B is a Full-Wave rectified configuration, which allows a maximum of 210VDC at 50 ADC continuous with an input voltage of 240VAC.

This connection is typically used on brushless and slip-ring generators with full load field voltages less than 125VDC and full load exciter field amperages between 25 and 50ADC.

Note that the maximum input voltage to the SE450 Static Exciter Module is 240VAC! DO NOT input 277VAC into the SE450! Severe damage to the unit will result! For use on 480V systems, either connect the SE450 to the winding center taps T7 and T8 or use a 480-240V step-down transformer.

Connecting the input of the SE450 to 2 different legs of the generator as shown in the diagram below will result in greater regulation accuracy than when connecting line-neutral.

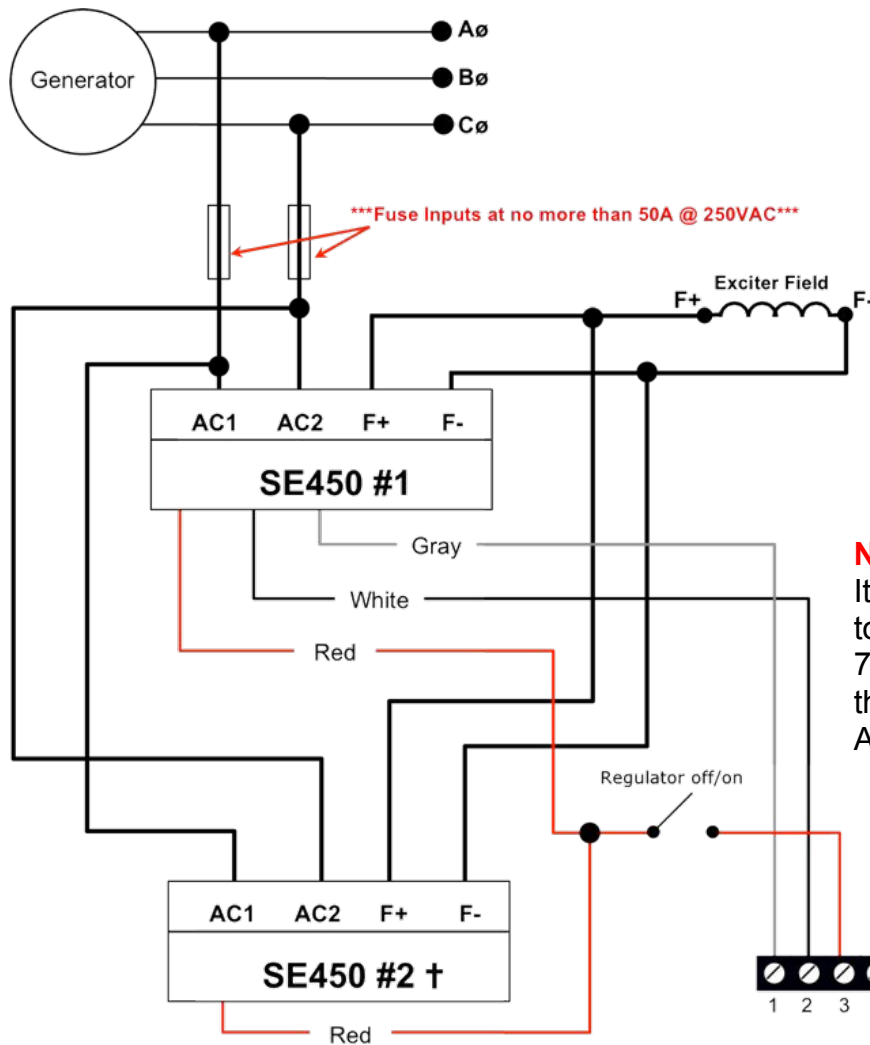

NOTE:

If the generator is to be operated below 50/60 Hz, a disconnect or switch should be installed in series with red wire of the SE450.

NEVER install a switch or breaker on the DC or Exciter side of the Static Exciter! Only install a switch or disconnect in the red wire, or on the AC side of the SE450!

NOTE:

It is not necessary to jumper terminals 7 and 8 if not using the Remote Voltage Adjustment!

Remote Voltage Adjustment
100KΩ @ 1/2W

XR or UVR Series Voltage Regulator, or UVR, XR, or PC series Phase Controller

† NOTE: Insulate and do not use the Gray and White wires from SE450 #2



Connection C

(See page 12 if the generator will be paralleled using this connection)

Connection C is a Full-Wave rectified configuration, which allows a maximum of 105VDC at 25 ADC continuous with an input voltage of 120VAC.

This is a very unusual connection for the SE450 Static Exciter and should be replaced with an SE350 Static Exciter with a 240V input if possible. This connection is typically used on generators with low voltage excitation fields with full load excitation voltage of less than 63VDC and exciter current between 5 and 25ADC.

Note that the maximum input voltage to the SE450 Static Exciter Module in this configuration is 139VAC! DO NOT input 208/240VAC into the SE450 in this configuration! Severe regulation problems and possible damage to the regulator or exciter field can result! For use on 480V systems, use a 480-120V step-down transformer.

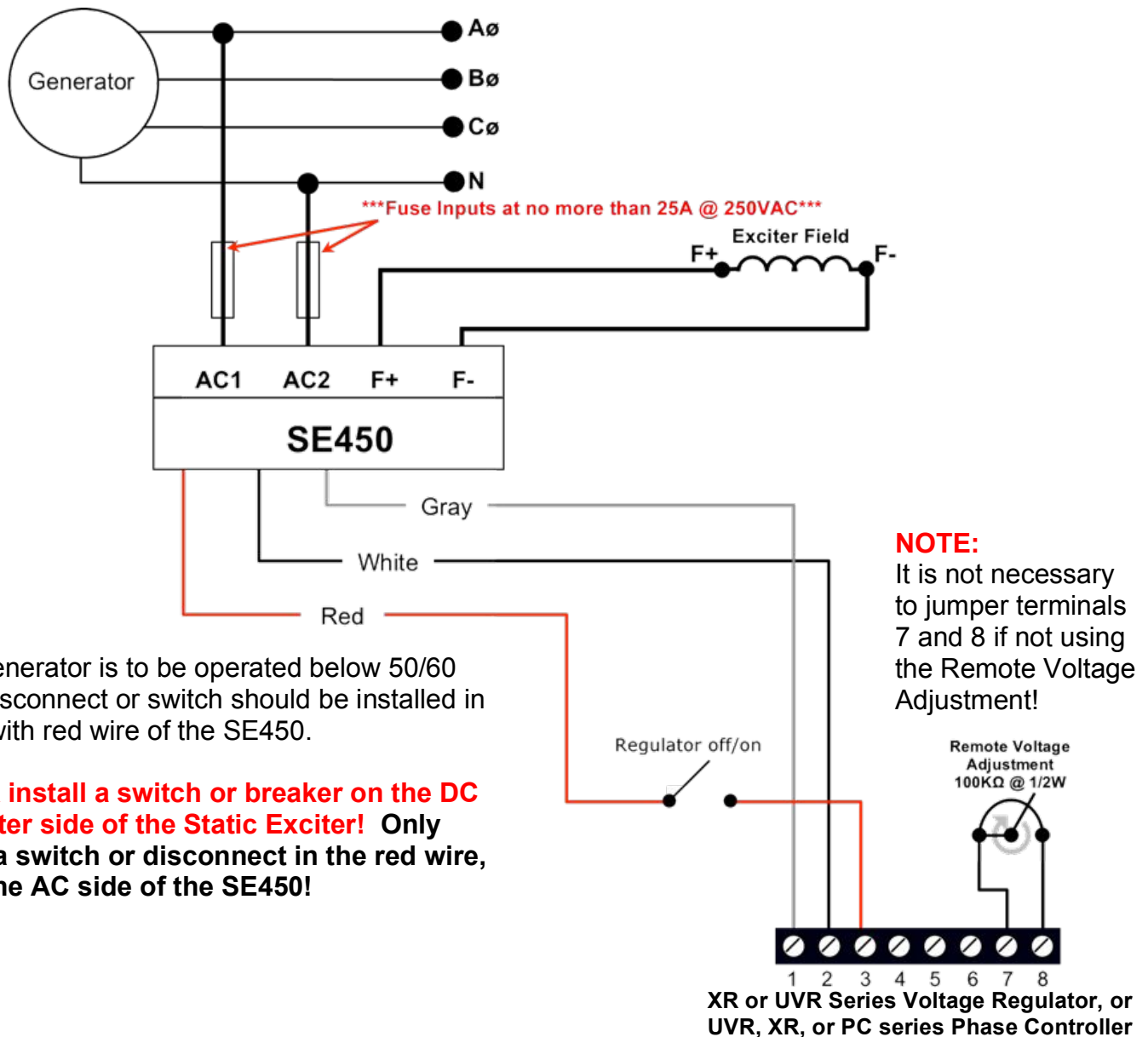



Connection D

(See page 12 if the generator will be paralleled using this connection)

Connection D is a Full-Wave rectified configuration, which allows a maximum of 105VDC at 50 ADC continuous with an input voltage of 120VAC.

This is a very unusual connection for the SE450 Static Exciter and should be replaced with 2 SE350 Static Exciters with a 240V input if possible. This connection is typically used on generators with low voltage excitation fields with full load excitation voltage of less than 63VDC and exciter current between 25 and 50ADC.

Note that the maximum input voltage to the SE450 Static Exciter Module in this configuration is 139VAC! DO NOT input 208/240VAC into the SE450 in this configuration! Severe regulation problems and possible damage to the regulator or exciter field can result! For use on 480V systems, use a 480-120V step-down transformer.

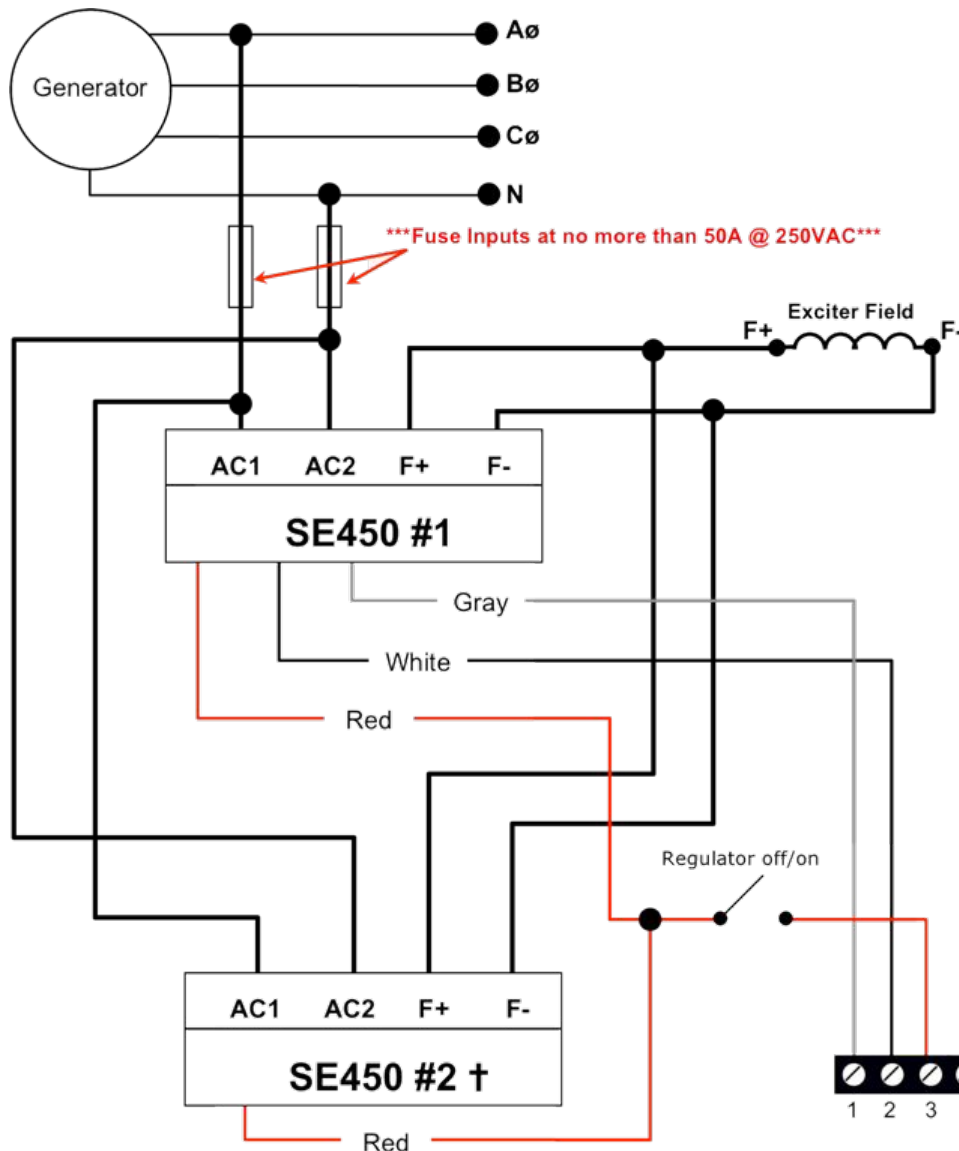

NOTE:

If the generator is to be operated below 50/60 Hz, a disconnect or switch should be installed in series with red wire of the SE450.

NEVER install a switch or breaker on the DC or Exciter side of the Static Exciter! Only install a switch or disconnect in the red wire, or on the AC side of the SE450!

NOTE:

It is not necessary to jumper terminals 7 and 8 if not using the Remote Voltage Adjustment!

Remote Voltage Adjustment
100KΩ @ 1/2W



1 2 3 4 5 6 7 8
XR or UVR Series Voltage Regulator, or UVR, XR, or PC series Phase Controller

† NOTE: Insulate and do not use the Gray and White wires from SE450 #2



Initial Setup and Commissioning

1. Install the regulator and SE450 module and wire up to the correct wiring diagram (Connection A, B, C, or D).
2. If installing the SE450 on a brush-type generator, verify that the brushes and brush riggings are isolated, ungrounded, and connected ONLY to the SE450.
3. Turn the internal voltage control on the voltage regulator 15 or more turns counter clockwise (left) or until you hear the screw click. This procedure is necessary in case the original factory settings have been altered.



Internal
voltage
adjustment

**Frequency Selection
(XR500C and XR500D)**
Remove jumper for 50Hz
operation. This product's
default setting is 60Hz.

(Pull up to remove)

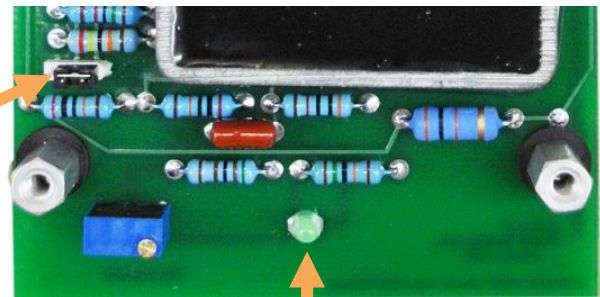

System
indicator light

4. If you are using a remote voltage adjustment, set it at 50% of adjustment.
5. If the generator is to be paralleled, set the droop resistor between 6Ω and 10Ω.
6. Start up the prime mover and bring up to operating speed and turn on the regulator switch (if used).
7. Set the internal voltage adjustment on the voltage regulator to the desired voltage setting for the generator output by turning the adjustment screw clockwise (right).
Note that the voltage adjustment is a 25-turn pot!
8. Place the generator on line and observe the frequency and voltage.
9. If the generator is being paralleled, measure the droop during loading and adjust the droop resistor as necessary. Reducing droop resistor resistance will reduce droop.
NOTE: Loading the generator with a purely resistive load-bank may cause undesirable droop characteristics such as no droop, very slight droop, or even rising terminal voltage. Measure droop with a mixed load for best results.
10. If paralleling and the terminal voltage rises or excessive amperage exportation occurs during loading with a mixed load connected, reverse the CT leads and try again.
11. Observe voltage regulation during no-load and full-load conditions. Once the voltage is set and regulating characteristics are satisfactory the installation procedure is complete.



Parallel Configuration for Connection A & B

To use the SE450 Static Exciter Module in a parallel configuration either with another generator or with a buss such as a utility, use the diagram below for proper hookup with the SE450 configured for Connection A or B.

NOTE: Power-Tronics products parallel using the Reactive Droop compensation method. This allows our products to parallel with existing systems easily while also allowing islanded operation with the flip of a switch. When initially installing the droop resistor, set it for approximately 7Ω before final adjustment later. If the droop is excessive when load testing, reduce the resistance a bit at a time until satisfactory droop is achieved. **CT should be sized at 25VA or larger capacity!**

NOTE:
If using Connection B,
refer to Page 7 for a
diagram of how to
connect your second
SE450 Module!

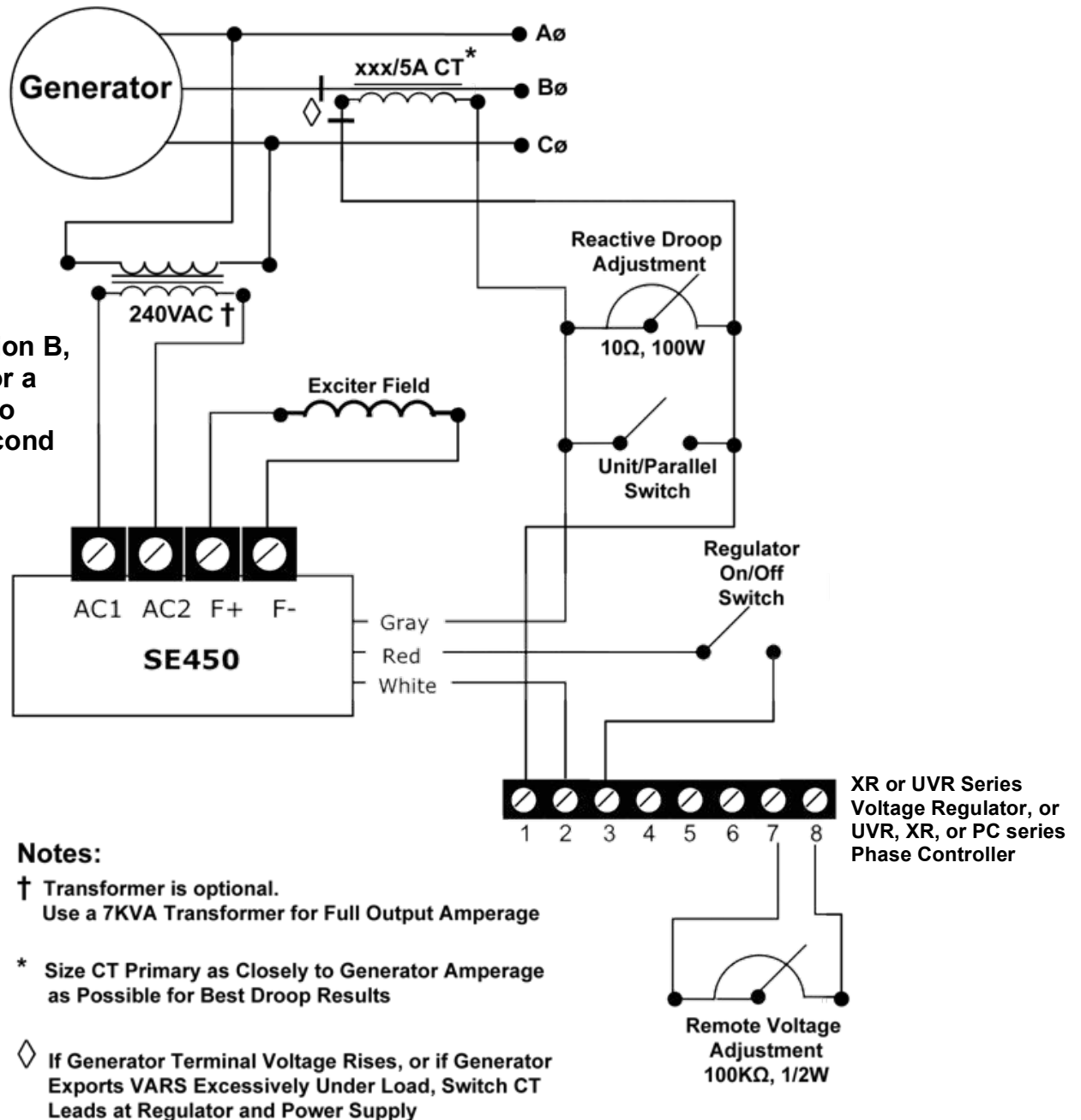



Parallel Configuration for Connection C & D

NOTE: This is an unusual connection for the SE450 Static Exciter Module and should be replaced with the SE350 Static Exciter Module with a 240V input voltage for the best possible performance and regulation accuracy!

To use the SE450 Static Exciter Module in a parallel configuration either with another generator or with a buss such as a utility, use the diagram below for proper hookup with the SE450 configured for Connection C or D.

NOTE: Power-Tronics products parallel using the Reactive Droop compensation method. This allows our products to parallel with existing systems easily while also allowing islanded operation with the flip of a switch. When initially installing the droop resistor, set it for approximately 7Ω before final adjustment later. If the droop is excessive when load testing, reduce the resistance a bit at a time until satisfactory droop is achieved. **CT should be sized at 25VA or larger capacity!**

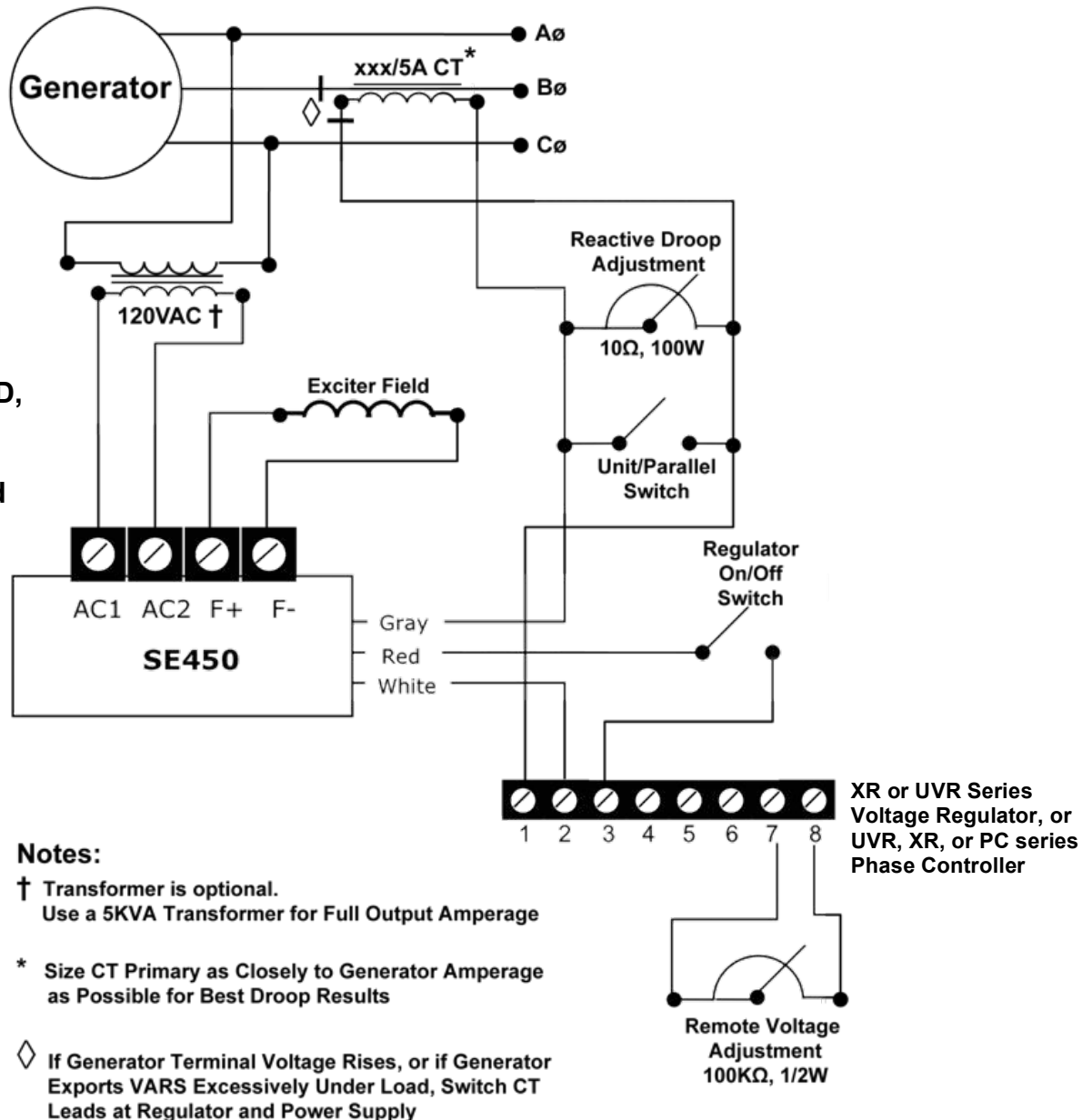

NOTE: If using Connection D, refer to Page 9 for a diagram of how to connect your second SE450 Module!



Optional Power-Tronics Add-On Modules

Power-Tronics offers a wide array of optional add-on modules for the SE450 Static Exciter Module from automatic flashing modules to digital interface cards. For more information on any of the modules below, visit our online catalog at:

www.power-tronics.com

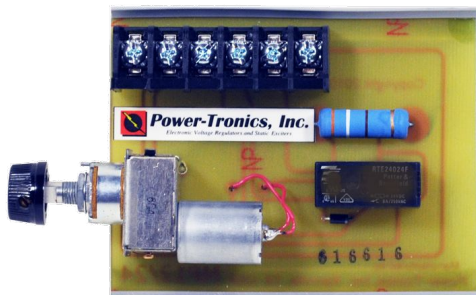

MP12/MP24

Motorized Potentiometer

Allows the XR500D to be externally controlled by older automated controllers using pulsed signals or dry contacts for control!



AFM500X

Automatic Flash Module

Adds Automatic Flash or Battery Flash to installations with low residual or requiring guaranteed buildup!



UIC200

Optical Interface Module

Allows the XR500D to be controlled externally by virtually any digital load-sharing controller, VAR controller, genset controller, or digital governor controller!



HVD1

High Voltage Disconnect Module

Saves your generator and connected equipment from runaway voltage conditions! Disconnects power to the voltage regulator instantly in the event of high voltage!



Application Troubleshooting

Problem:

Possible Cause

No Voltage	1 3 5 7 9 11 13 15 20
Pulsating Voltage	4 5 6 12 16 20
Flickering Voltage	4 6 7 14 20
High Voltage	6 7 8 9 12 13 17 18 20
Voltage Drop on Load	5 8 10 12 16
Low Voltage	5 8 12 13
Poor Voltage Regulation	2 4 10 12 13 16 20
No Voltage Control	13 19 20

Possible Causes:

-
1. Residual input voltage to the voltage regulator is below 3.5vac or fuses are open in the regulator.
 2. Unbalanced generator load.
 3. Open exciter field or defective generator.
 4. Non linear load or defective connection in exciter field.
 5. Open diode in exciter or shorted rotor in generator.
 6. Loose component in voltage regulator.
 7. Loose wiring connections.
 8. Input voltage to regulator is too low.
 9. Exciter field is grounded.
 10. Non linear load or wrong selection for regulator hookup.
 11. Exciter fields are reversed.
 12. Wrong selection of regulator wiring configuration.
 13. Defective voltage regulator.
 14. SCR or Inverter drive effecting generator waveform.
 15. Regulator needs external flashing circuit.
 16. Isolation transformer is too small.
 17. Isolation transformer is needed.
 18. Exciter fields are not isolated from other circuits.
 19. Input and field circuit are being fed by a common cable or conduit.
 20. Incorrect hookup or wiring.



Bench Check Procedures

1. Wire up the SE450 as shown in the figure below.
2. Connect up a 120 volt 50 to 150 watt light bulb to the F+ and F- Terminals.
3. Tape off and insulate the Gray and White wires.
4. Connect a 1000Ω resistor to the red wires on the SE450.
5. Input 120VAC fused at no more than 5A into the SE450. **The test light should be OFF.**
6. Touch the 1000Ω resistor connected to the red wire to the AC1 terminal. **The test light should light to HALF Brightness.**
7. Touch the 1000Ω resistor connected to the red wire to the AC2 terminal. **The test light should light to HALF Brightness.**
8. Disconnect the 1000Ω resistor and red wire from the AC1 terminal. **The test light should be OFF.**
9. Turn off power and disconnect the SE450 from your power source. Inspect all electronic components on the SE450 to ensure they are isolated from touching any part of the SE450 housing.
10. **If you were able to successfully perform all of these tests, the SE450 is good.**

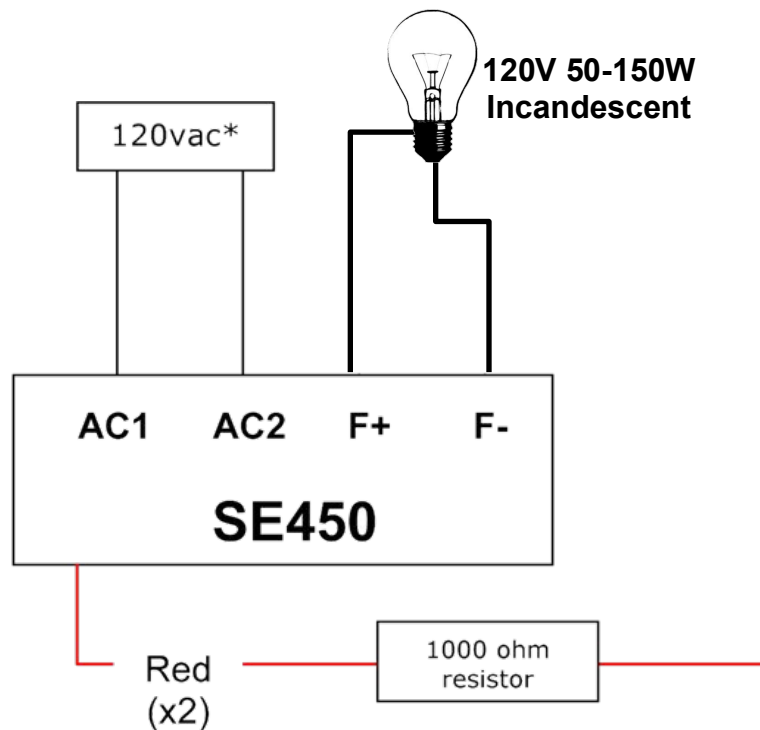

* Fuse this input with a 1 or 2 amp 120vac fuse.



Installation Warranty Form

It is very important that you fill out this form completely when installing a voltage regulator. This form serves as a history record on the application. This form also contains the information needed by Power-Tronics, Inc., for repair and troubleshooting of any product you may be having problems with.

Failure to fill out this form during installation will result in a cancellation of your warranty coverage! Filling out this form takes only minutes but will save hours or days later on if your product should require service!

Product		Other options		
Serial Number				
Date of Installation				
Type of Generator			Model #	
	Brush type	<input type="checkbox"/>		
	Brushless	<input type="checkbox"/>		
AC Stator Information				
Wired for	Volts	Phase	Hz	
Generator Configuration: Lead				
Exciter/Rotor Information				
Exciter field resistance		Ω	@ F+ / F-	Ω
Exciter field volts		vdc	@ Slip Rings	Ω
Description of problem with product or generator				
Your phone number		Name:		
Your fax number		Ship to Address:		
Your email address		Ship to City, State, Zip:		



PRODUCT WARRANTY

Power-Tronics, Inc., assumes no liability for damages due to incorrect voltage or other voltage related damages resulting from either output of the generator or input to the generator exciter system. These problems should be protected with external devices provided by the customer such as **fuses, surge suppressors, over/under voltage and frequency controls.**

Power-Tronics, Inc., warranties **only parts and workmanship** of this product for a **period of 2 years from the original date of purchase from Power-Tronics, Inc.** Under warranty, Power-Tronics, Inc. will replace, exchange or repair the defective product **without labor or parts cost to the customer.** Remaining warranty of the original product will be transferred to the replaced or repaired product. To obtain warranty, a copy of the original Installation Warranty Form must be sent in with the defective product, which clearly shows the purchase date and serial number of the defective part. A repair request form must be sent in with the product before repairs will begin. You can obtain this form by contacting Power-Tronics, Inc.

Send repairs to: Power-Tronics, Inc., 2802 Cobbler Ln., Kerrville Texas USA 78028.

***Send in repairs only by UPS or FedEx.* USPS will NOT deliver to our facility!**

Any one of the following conditions will void the warranty:

- ❖ Overheating of the power supply resistor on the printed circuit card.
- ❖ Overheating of the SCR or freewheeling diode.
- ❖ Physical damage to the printed circuit card, housing or components.
- ❖ Unauthorized repair or alteration of printed circuit card.
- ❖ Installation by anyone other than a qualified professional generator service technician.
- ❖ Conductive or corrosive contamination of the circuit card.
- ❖ Removal of our company identification from the product.
- ❖ Removal of any conformal coating of the printed circuit card or components.
- ❖ Overheating of foil on the printed circuit card.
- ❖ Inappropriate or infeasible application.
- ❖ Use with any external device other than manufactured by Power-Tronics, Inc.
- ❖ Failure to fill out the attached warranty card during installation

No other warranty is expressed or implied.