



SEM100A

Static Exciter Module



The Power-Tronics SEM100A Static Exciter Module is a self-contained external rectifier assembly for all Power-Tronics XR and UVR series voltage regulators. The SEM100A Static Exciter Module allows a standard Power-Tronics voltage regulator to control exciter fields with current requirements up to 100 amps DC at 105VDC!

The SEM100A is a unique design, intended to offer the capacity of a full static exciter while reducing its physical footprint for installations with space restrictions.

The SEM100A is a very robust design and is intended to operate for a lifetime. However, should repair ever be necessary, the SEM100A is extremely simple to repair, minimizing downtime!

The SEM100A Static Exciter is compatible with all Power-Tronics UVR, XR, and certain older VR series voltage regulators, as well as the Power-Tronics PC500X, UVR500PC, and XR500PC phase controllers!

Specifications

Input Voltage:	208-240vac
Frequency:	N/A
Output Voltage:	0-105vdc @ 240vac input
Maximum Continuous Output:	90adc
Maximum Forcing Output:	100adc
Minimum Field Resistance:	1.05Ω @ 105vdc output
Physical Size:	10 x 10 x 8 in.
Weight:	8 lbs
Repairable:	Yes



Table of Contents

Introduction and Functional Description:.....	3
Determining Application Sizing:.....	4
Hookup Diagram:.....	6
Parallel Hookup Diagram:.....	7
Initial Setup and Commissioning:.....	8
Optional Power-Tronics Add-On Modules:.....	9
Application Troubleshooting:.....	10
Bench Check Procedures:.....	11
Installation Warranty Form:.....	12
Product Warranty Certificate:.....	13



Introduction and Functional Description

Caution: Read This Installation Manual Carefully and Entirely!

Warning: Do not use digital equipment to read voltage, Hz, or amperage during this installation. Use only Analog sensing equipment! Failure to do so may result in damage to equipment or in personal injury!

ALWAYS perform all setup procedures off-line

ALWAYS wear eye protection

ALWAYS strip wire insulation properly or use insulated connectors

ALWAYS use analog metering equipment when setting up the exciter

ALWAYS ensure the exciter receives ample airflow

ALWAYS use adequate fusing

NEVER hold the regulator in your hand when energized

NEVER install the exciter in a place it can get wet or is exposed to the elements

NEVER mount the exciter over a screw, bolt, rivet, welding seam, or other fastener

NEVER insert a screwdriver or other object into any part of the SEM100A

NEVER touch any exposed part of the SEM100A during operation

NEVER install a switch in the DC portion of the exciter's wiring

NEVER USE A DIGITAL FREQUENCY METER (It can give a false reading!)

Functional Description

The SEM100A Static Exciter Module has a proven track record of over 20 years of extreme reliability and robustness. It offers an inexpensive and unique way to upgrade a standard voltage regulator to a reduced size static exciter with a minimum of connections and a minimum of installation space.

The SEM100A is designed to work with Power-Tronics UVR and XR series voltage regulators and UVR, XR, and PC series phase controllers. Coupled with one of these products, the SEM100A allows field excitation of 105VDC at 90ADC continuous.

Regulation accuracy depends on the voltage regulator the SEM100A is used with. If used with the XR500D series Universal Voltage Regulator, the voltage regulation will be within +/-0.25%. Other voltage regulators will regulate within their printed specifications.

The SEM100A does not contain internal fusing and must be fused externally. Always use 100A 250VAC fast-blow fuses (such as JJN or Type J fuses) with the SEM100A Static Exciter Module! Failure to fuse the SEM100A properly will void your warranty!



Determining Application Sizing

***STOP!* DO NOT use the instruction manual that came with your voltage regulator when using the SEM100A Static Exciter Module! Use this manual instead! It contains the most up to date information available regarding your product!**

The SEM100A Static Exciter Module is designed for use with 208-240VAC input. It contains internal suppression for use with brush-type generator sets. Before installation, it is necessary to verify that the SEM100A is the correct product for your application.

To determine if the SEM100A is the correct product for your generator you need to know any two of the following 3 specifications from the rating plate of your generator:

- 1: Exciter Field Voltage (in DC Volts) [Generally given in full load Voltage on nameplates]
- 2: Exciter Field Resistance (in Ohms) [**See Note Below**]
- 3: Exciter Field Amperage (in DC Amps) [Generally given in full load Amps on nameplates]

Using the specifications obtained from your generator exciter, verify that your generator fits the specifications from the chart or graph below:

- Exciter full load voltage is 63VDC or less, and your exciter field resistance is 1.05Ω or greater.

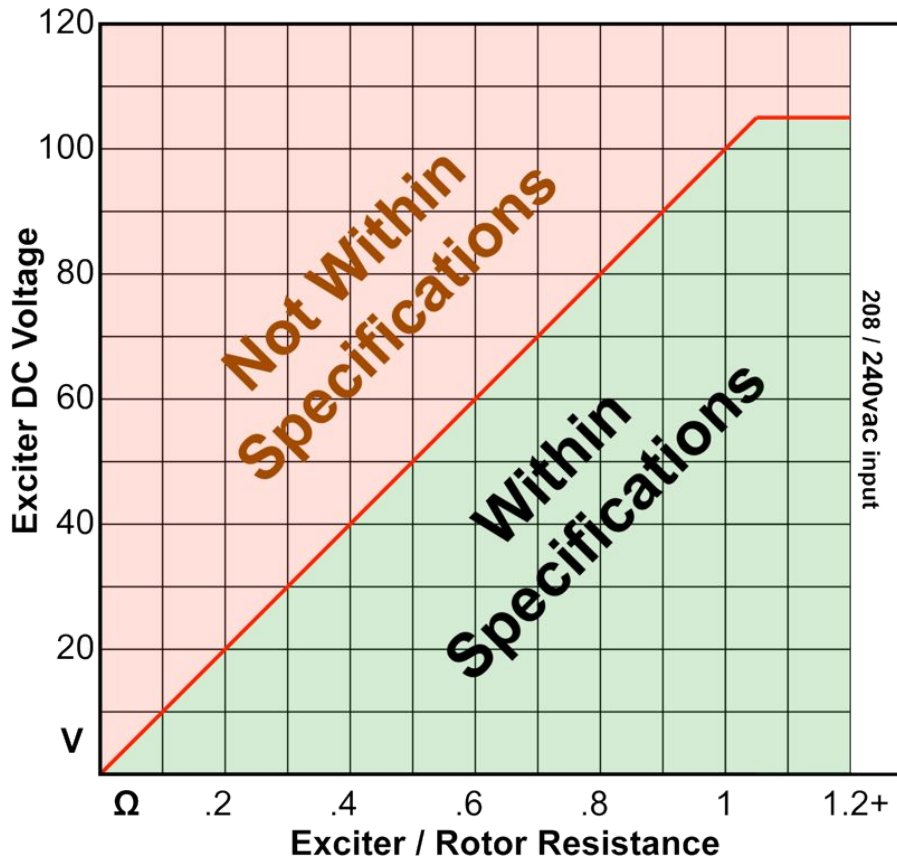



Note about Field Resistance:

- When measuring field resistance on a brushless generator, simply measure the resistance of the exciter field through your field leads with a multimeter.
- When measuring field resistance on a brush-type generator, measure the resistance through both the field leads as well as directly on the slip rings themselves. **The readings you obtain should ideally be the same, but no more than 1% difference.** If you show more than 1% difference in reading your generator has brush and ring contact problems and will need cleaning or maintenance before installing the SEM100A. **Failure to correct brush and ring contact problems will result in severe damage to the voltage regulator as well as possible PERMANENT damage to the slip rings themselves!** NEVER use emery cloth, carborundum stones, “comm sticks”, or Tuner cleaner to dress or clean slip rings. They will make a bad problem much, much worse! Only use Garnet or Flint sandpaper and clean with a clean rag soaked with Acetone for best results!

If you do not have any of the specifications of your generator’s exciter, or if you don’t know where to start when trying to determine your exciter specs, please see the section below for instructions on measuring and calculating your exciter specifications.

- Measure your exciter field resistance using a multimeter on your field leads. Record this value. If you have a brush-type generator, also take a resistance reading on your slip rings: the value you obtain on the slip rings should be no more than 1% difference from the value you obtained through the field leads.
- Next, start and run the generator and apply 12V from a battery through your field leads and record the AC voltage produced by the generator. To determine your full load exciter field voltage, use the following formula:

$$E_{Exc.} = \frac{E_{Gen.Conf.}}{\left(\frac{E_{Gen.Output}}{E_{Battery}} \right)} * 2$$

Where $E_{Gen.Conf.}$ is your Generator’s configured voltage (e.g.: 120, 208, 240, 480V, etc.), $E_{Gen.Output}$ is your recorded output voltage, and $E_{Battery}$ is your battery voltage (12V usually).

- Next, calculate your maximum exciter field amperage using your measured field resistance and your calculated exciter voltage using the following formula:

$$I = \frac{E}{R}$$

Where I is your maximum exciter field current, E is your calculated field voltage from the above formula, and R is your measured field resistance.

Using the values you just measured and calculated, see the chart on the previous page to determine whether the SEM100A is the correct product for your application.



Connection Diagram

(See page 7 if the generator will be paralleled using this product)

The SEM100A is a Half-Wave rectified static exciter, which allows a maximum of 105VDC at 90 ADC continuous with an input voltage of 240VAC.

This product is typically used on slip-ring generators with full load field voltages of 63VDC or less and full load exciter field amperages between 30 and 90ADC.

Note that the maximum input voltage to the SEM100A Static Exciter Module is 240VAC! DO NOT input 277VAC into the SEM100A! Severe damage to the unit will result! For use on 480V systems, either connect the SEM100A to the winding center taps T7 and T8 or use a 480-240V step-down transformer.

Connecting the input of the SEM100A to 2 different legs of the generator as shown in the diagram below will result in greater regulation accuracy than when connecting line-neutral.

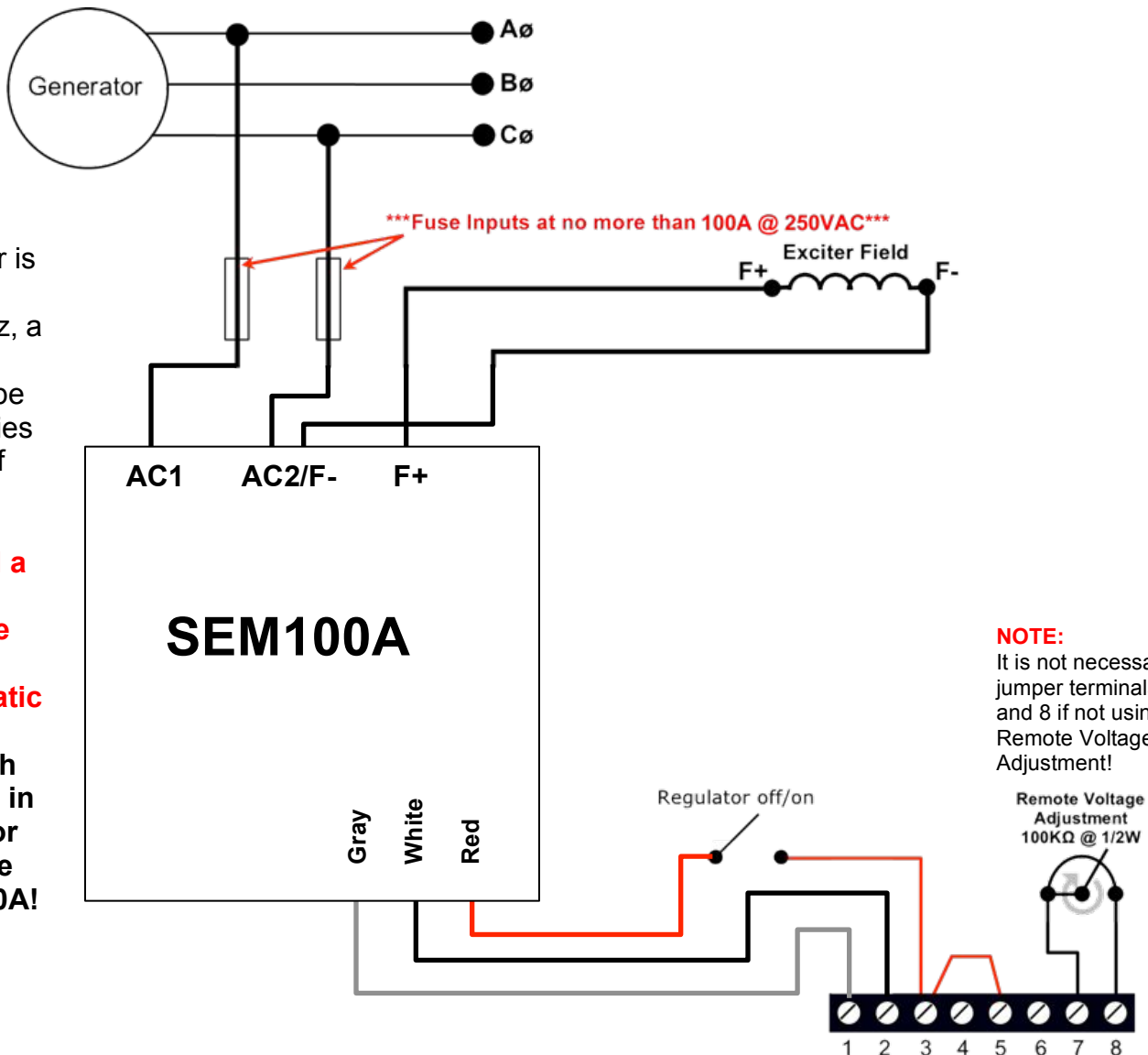

NOTE:

If the generator is to be operated below 50/60 Hz, a disconnect or switch should be installed in series with red wire of the SEM100A.

NEVER install a switch or breaker on the DC or Exciter side of the Static Exciter! Only install a switch or disconnect in the red wire, or on the AC side of the SEM100A!

Fuse Inputs at no more than 100A @ 250VAC

NOTE:
It is not necessary to jumper terminals 7 and 8 if not using the Remote Voltage Adjustment!

Remote Voltage Adjustment
100KΩ @ 1/2W

1 2 3 4 5 6 7 8
XR or UVR Series Voltage Regulator, or UVR, XR, or PC series Phase Controller



Parallel Connection Diagram

To use the SEM100A Static Exciter Module in a parallel configuration either with another generator or with a buss such as a utility, use the diagram below for proper hookup with the SEM100A.

NOTE: Power-Tronics products parallel using the Reactive Droop compensation method. This allows our products to parallel with existing systems easily while also allowing islanded operation with the flip of a switch. When initially installing the droop resistor, set it for approximately 7Ω before final adjustment later. If the droop is excessive when load testing, reduce the resistance a bit at a time until satisfactory droop is achieved. **CT should be sized at 25VA or larger capacity!**

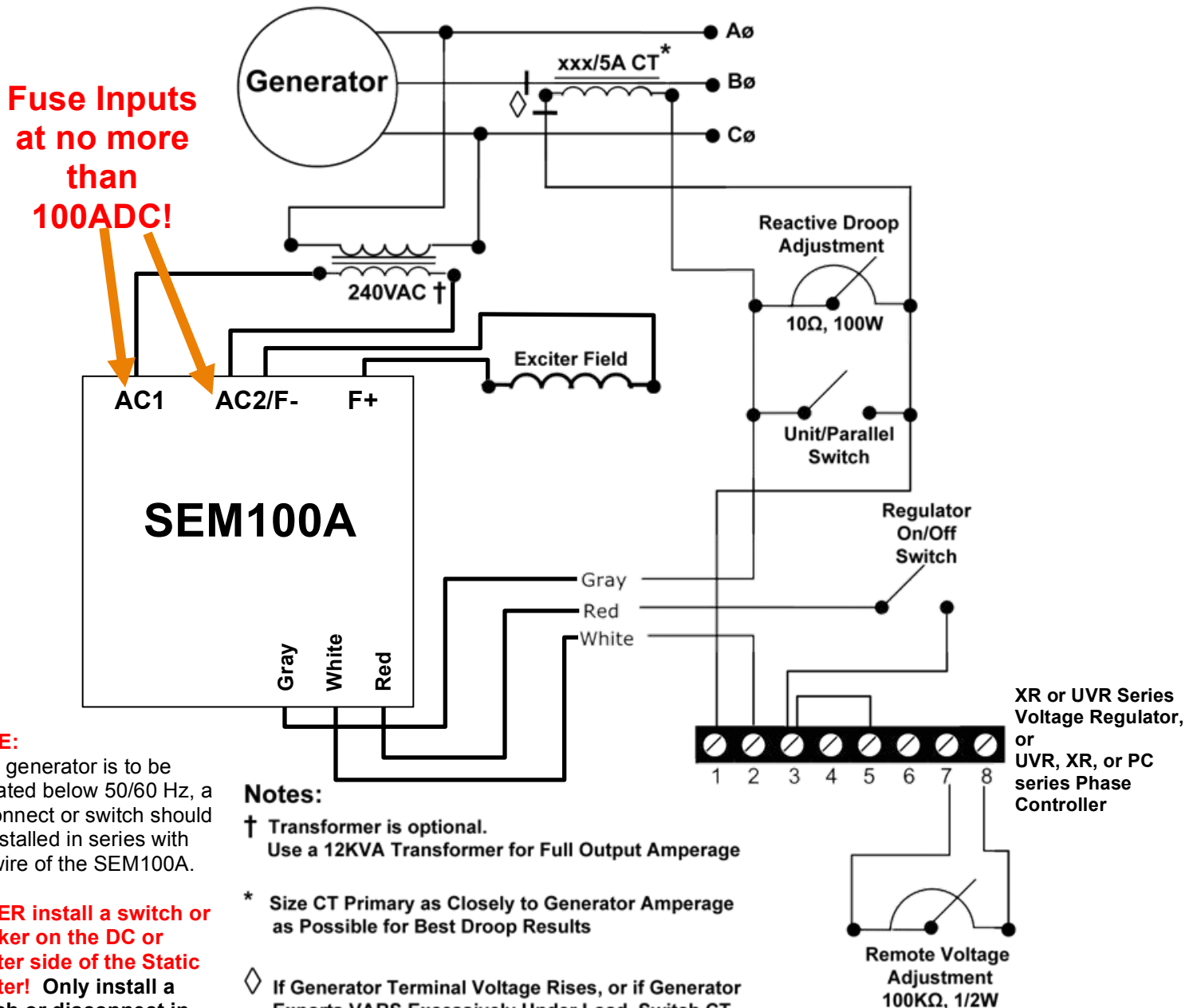

Fuse Inputs at no more than 100ADC!

NOTE:
If the generator is to be operated below 50/60 Hz, a disconnect or switch should be installed in series with red wire of the SEM100A.

NEVER install a switch or breaker on the DC or Exciter side of the Static Exciter! Only install a switch or disconnect in the red wire, or on the AC side of the SEM100A!

Notes:

† Transformer is optional.
Use a 12KVA Transformer for Full Output Amperage

* Size CT Primary as Closely to Generator Amperage as Possible for Best Droop Results

◇ If Generator Terminal Voltage Rises, or if Generator Exports VARS Excessively Under Load, Switch CT Leads at Regulator and Power Supply

NOTE:
It is not necessary to jumper terminals 7 and 8 if not using the Remote Voltage Adjustment!



Initial Setup and Commissioning

1. Install the regulator and SEM100A module and wire up to the connection diagram.
2. If installing the SEM100A on a brush-type generator, verify that the brushes and brush rigging are isolated, ungrounded, and connected ONLY to the SEM100A.
3. Turn the internal voltage control on the voltage regulator 15 or more turns counter clockwise (left) or until you hear the screw click. This procedure is necessary in case the original factory settings have been altered.



Internal
voltage
adjustment

**Frequency Selection
(XR500C and XR500D)**
Remove jumper for 50Hz
operation. This product's
default setting is 60Hz.

(Pull up to remove)

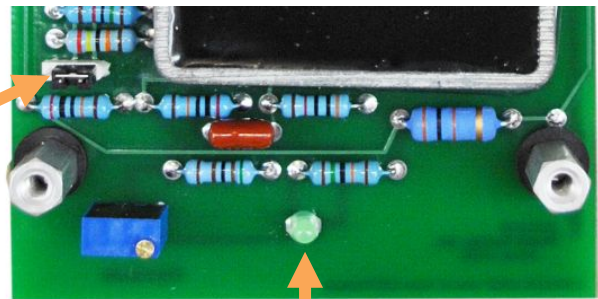

System
indicator light

4. If you are using a remote voltage adjustment, set it at 50% of adjustment.
5. If the generator is to be paralleled, set the droop resistor between 6Ω and 10Ω.
6. Start up the prime mover and bring up to operating speed and turn on the regulator switch (if used).
7. Set the internal voltage adjustment on the voltage regulator to the desired voltage setting for the generator output by turning the adjustment screw clockwise (right).
Note that the voltage adjustment is a 25-turn pot!
8. Place the generator on line and observe the frequency and voltage.
9. If the generator is being paralleled, measure the droop during loading and adjust the droop resistor as necessary. Reducing droop resistor resistance will reduce droop.
NOTE: Loading the generator with a purely resistive load-bank may cause undesirable droop characteristics such as no droop, very slight droop, or even rising terminal voltage. Measure droop with a mixed load for best results.
10. If paralleling and the terminal voltage rises or excessive amperage exportation occurs during loading with a mixed load connected, reverse the CT leads and try again.
11. Observe voltage regulation during no-load and full-load conditions. Once the voltage is set and regulating characteristics are satisfactory the installation procedure is complete.



Optional Power-Tronics Add-On Modules

Power-Tronics offers a wide array of optional add-on modules for the SEM100A Static Exciter Module from automatic flashing modules to digital interface cards. For more information on any of the modules below, visit our online catalog at:

www.power-tronics.com

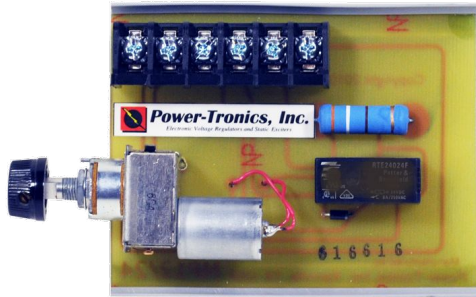

MP12/MP24

Motorized Potentiometer

Allows the XR500D to be externally controlled by older automated controllers using pulsed signals or dry contacts for control!



AFM500X

Automatic Flash Module

Adds Automatic Flash or Battery Flash to installations with low residual or requiring guaranteed buildup!



UIC200

Optical Interface Module

Allows the XR500D to be controlled externally by virtually any digital load-sharing controller, VAR controller, genset controller, or digital governor controller!



HVD1

High Voltage Disconnect Module

Saves your generator and connected equipment from runaway voltage conditions! Disconnects power to the voltage regulator instantly in the event of high voltage!



Application Troubleshooting

Problem:

Possible Cause

No Voltage	1 3 5 7 9 11 13 15 20
Pulsating Voltage	4 5 6 12 16 20
Flickering Voltage	4 6 7 14 20
High Voltage	6 7 8 9 12 13 17 18 20
Voltage Drop on Load	5 8 10 12 16
Low Voltage	5 8 12 13
Poor Voltage Regulation	2 4 10 12 13 16 20
No Voltage Control	13 19 20

Possible Causes:

-
1. Residual input voltage to the voltage regulator is below 3.5vac or fuses are open in the regulator.
 2. Unbalanced generator load.
 3. Open exciter field or defective generator.
 4. Non linear load or defective connection in exciter field.
 5. Open diode in exciter or shorted rotor in generator.
 6. Loose component in voltage regulator.
 7. Loose wiring connections.
 8. Input voltage to regulator is too low.
 9. Exciter field is grounded.
 10. Non linear load or wrong selection for regulator hookup.
 11. Exciter fields are reversed.
 12. Wrong selection of regulator wiring configuration.
 13. Defective voltage regulator.
 14. SCR or Inverter drive effecting generator waveform.
 15. Regulator needs external flashing circuit.
 16. Isolation transformer is too small.
 17. Isolation transformer is needed.
 18. Exciter fields are not isolated from other circuits.
 19. Input and field circuit are being fed by a common cable or conduit.
 20. Incorrect hookup or wiring.



Bench Check Procedures

1. Wire up the SEM100A as shown in the figure below.
2. Connect up a 120 volt 50 to 150 watt light bulb to the F+ and F- Terminals.
3. Connect a 1000 Ω resistor to the red wire on the SEM100A.
4. Input 120VAC fused at no more than 5A into the SEM100A. **The test light should be OFF.**
5. Touch the 1000 Ω resistor connected to the red wire to the gray wire terminal. **The test light should light to HALF Brightness.**
6. Disconnect the 1000 Ω resistor and red wire from the gray wire terminal. **The test light should be OFF.**
7. Turn off power and disconnect the SEM100A from your power source. Inspect all electronic components on the SEM100A to ensure they are isolated from touching any part of the SEM100A housing or heatsinks.
8. **If you were able to successfully perform all of these tests, the SEM100A is good.**

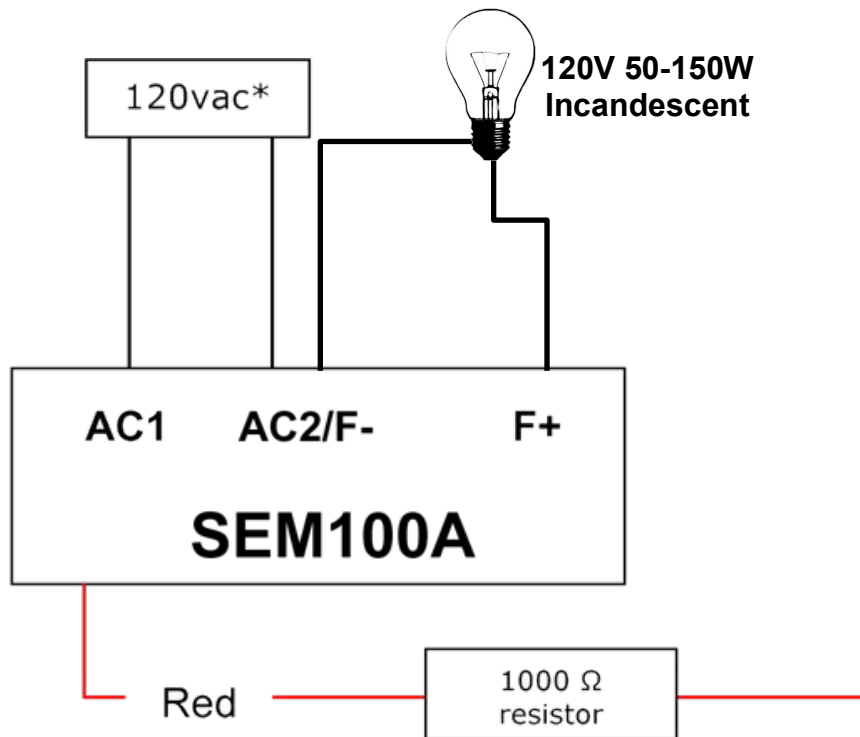

*** Fuse this input with a 5 amp 120vac fuse.**



Installation Warranty Form

It is very important that you fill out this form completely when installing a voltage regulator. This form serves as a history record on the application. This form also contains the information needed by Power-Tronics, Inc., for repair and troubleshooting of any product you may be having problems with.

Failure to fill out this form during installation will result in a cancellation of your warranty coverage! Filling out this form takes only minutes but will save hours or days later on if your product should require service!

Product		Other options			
Serial Number					
Date of Installation					
Type of Generator				Model #	
	Brush type	<input type="checkbox"/>			
	Brushless	<input type="checkbox"/>			
AC Stator Information					
Wired for	Volts	Phase	Hz		
Generator Configuration: Lead					
Exciter/Rotor Information					
Exciter field resistance		Ω		@ F+ / F-	Ω
Exciter field volts		vdc		@ Slip Rings	Ω
Description of problem with product or generator					
Your phone number			Name:		
Your fax number			Ship to Address:		
Your email address			Ship to City, State, Zip:		



PRODUCT WARRANTY

Power-Tronics, Inc., assumes no liability for damages due to incorrect voltage or other voltage related damages resulting from either output of the generator or input to the generator exciter system. These problems should be protected with external devices provided by the customer such as **fuses, surge suppressors, over/under voltage and frequency controls.**

Power-Tronics, Inc., warrants **only parts and workmanship** of this product for a **period of 2 years from the original date of purchase from Power-Tronics, Inc.** Under warranty, Power-Tronics, Inc. will replace, exchange or repair the defective product **without labor or parts cost to the customer.** Remaining warranty of the original product will be transferred to the replaced or repaired product. To obtain warranty, a copy of the original Installation Warranty Form must be sent in with the defective product, which clearly shows the purchase date and serial number of the defective part. A repair request form must be sent in with the product before repairs will begin. You can obtain this form by contacting Power-Tronics, Inc.

Send repairs to: Power-Tronics, Inc., 2802 Cobbler Ln., Kerrville Texas USA 78028.

***Send in repairs only by UPS or FedEx.* USPS will NOT deliver to our facility!**

Any one of the following conditions will void the warranty:

- ❖ Overheating of the power supply resistor on the printed circuit card.
- ❖ Overheating of the SCR or freewheeling diode.
- ❖ Physical damage to the printed circuit card, housing or components.
- ❖ Unauthorized repair or alteration of printed circuit card.
- ❖ Installation by anyone other than a qualified professional generator service technician.
- ❖ Conductive or corrosive contamination of the circuit card.
- ❖ Removal of our company identification from the product.
- ❖ Removal of any conformal coating of the printed circuit card or components.
- ❖ Overheating of foil on the printed circuit card.
- ❖ Inappropriate or infeasible application.
- ❖ Use with any external device other than manufactured by Power-Tronics, Inc.
- ❖ Failure to fill out the attached warranty card during installation

No other warranty is expressed or implied.