



XR500D

Universal Voltage Regulator



The Power-Tronics XR500D Universal Voltage Regulator is the latest upgrade for all UVR and XR series voltage regulators. The XR500D is also capable of replacing other manufacturers' voltage regulators and has optional Static Exciter Modules to boost its capacity to 30 amps DC!

The XR500D is a unique, Universal voltage regulator that is designed specifically for Professional Electrical Generator Service Technicians and the Electrical Generator Repair Industry. It incorporates an easily selectable frequency range for voltage roll-off during under-frequency operation and offers precise voltage regulation regardless of the connected load and ambient temperature. The XR500D is a ruggedized design and is engineered to provide a lifetime of trouble-free operation.

The XR500D contains patented electronic circuitry that automatically matches the regulator's response time to the generator exciter. This unique innovation eliminates the need to manually adjust stability when setting up the voltage regulator and greatly simplifies installation.

PLC and automated Genset control is possible with the XR500D by simply adding an optional, inexpensive digital interface module. This capability makes the XR500D suitable for automated or unattended installations, or large-scale parallel operations.

Like our previous models, the XR500D is fully repairable! All major electronic components are not encapsulated to facilitate repair while all sensitive components are encapsulated to protect them from contamination and moisture.

The XR500D is compatible with all previous and current optional modules available for use with Power-Tronics voltage regulators making it extremely simple to upgrade an older voltage regulator installation with the modern features offered by the XR500D.

Specifications

Input Voltage:	120 / 208 or 240vac
Frequency:	50 or 60hz
Voltage Regulation:	+/- .25% From NL to FL
Parallel Operation	Yes
Output Voltage:	0-52vdc @ 120vac input 0-105vdc @ 240vac input 0-210vdc @ 240vac input
Maximum Continuous Output:	5adc
Minimum Field Resistance:	10.5Ω @ 52vdc output 21Ω @ 105vdc output 42Ω @ 210vdc output
Min Residual Build up Voltage:	3.5vac
Under Frequency Protection:	Yes, VPH reduction
Physical Size:	4.75 x 6 x 1 in.
Weight:	7 oz
Repairable:	Yes
Internal Protection:	Fuses, cartridge type
External Voltage Adjustment:	Yes
System Operating Indicator:	Yes
Optional Static Exciter Modules	Yes
Optional External Controls	Yes



Table of Contents

Introduction and Functional Description:.....	3
Determining Which Hookup Configuration to Use:.....	4
Use with PMG's, DPE, AUX, and Harmonic Winding Generators:.....	6
Hookup Connection A:.....	7
Hookup Connection B:.....	8
Hookup Connection C:.....	9
Initial Setup and Commissioning:.....	10
Parallel Configuration for Connection A:.....	11
Parallel Configuration for Connection B:.....	12
Parallel Configuration for Connection C:.....	13
Optional Power-Tronics Add-On Modules:.....	14
Conversion From Shunt-Wound to Solid-State Regulation:.....	15
Internal Fuse Replacement:.....	16
Application Troubleshooting:.....	17
Bench Check Procedures:.....	18
Installation Warranty Form:.....	19
Product Warranty Certificate:.....	20



Introduction and Functional Description

Caution: Read This Installation Manual Carefully and Entirely!

Warning: Do not use digital equipment to read voltage, Hz, or amperage during this installation. Use only Analog sensing equipment! Failure to do so may result in damage to equipment or in personal injury!

ALWAYS perform all setup procedures off-line

ALWAYS wear eye protection

ALWAYS strip wire insulation properly or use insulated connectors

ALWAYS use analog metering equipment when setting up the regulator

ALWAYS ensure the regulator receives ample airflow

NEVER hold the regulator in your hand when energized

NEVER install the regulator in a place it can get wet or is exposed to the elements

NEVER mount the regulator over a screw, bolt, rivet, welding seam, or other fastener

NEVER remove the regulator cover while the unit is in operation

NEVER insert a screwdriver or other object under the regulator cover

NEVER install a switch in the DC portion of the regulator's wiring

NEVER USE A DIGITAL FREQUENCY METER (It can give a false reading!)

Functional Description

The XR500D Universal Voltage Regulator is the result of over 20 years of engineering efforts and offers high-demand features at a competitive price point. The XR500D is a proven design and is engineered to greatly simplify setup while offering extreme reliability. When properly installed, the XR500D Universal Voltage Regulator is designed to provide a lifetime of service.

A Generator voltage regulator has several automated tasks it must perform in order to provide reliable, clean, and regulated electricity. It must build-up the generator, regulate the terminal voltage within its design specifications, and protect both itself and the generator should a fault situation arise.

The XR500D contains a time-proven, extremely reliable circuit for build-up functionality. Due to its simplicity, the XR500D is able to build up generators with residual voltages from 3.5VAC without initial overshoot or excessive delay. The patented circuitry contained in the XR500D automatically adjusts the regulator to match the generator's response time, minimizing setup complexity while maximizing load acceptance and rejection performance. The XR500D is also a precision voltage regulator and is capable of regulating the terminal voltage of the generator within +/- .25% of its initial set point.

The XR500D uses field-replaceable 20mm glass cartridge fuses to protect its internal circuitry should a fault occur and the exciter field current exceeds what the regulator is capable of delivering. It also contains a unique frequency-selectable Volts-Per-Hertz circuit, which helps a turbo-charged engine accept a large load, and also helps to protect the generator rotor and exciter if the engine is idled with the regulator still energized.

Due to its extreme simplicity, the XR500D Universal Voltage Regulator is uncommonly reliable and offers features and regulation accuracy usually only offered by much more complicated and often much more expensive regulators.



Determining Which Hookup Configuration to Use

STOP! If you are using an optional SE350 or SE450 Static Exciter Module, **DO NOT** use these instructions for hookup! See the instructions that came with your module instead!

The XR500D Universal Voltage Regulator is configurable for 3 different output ranges suitable for use on the vast majority of generators available on the market from past and present. It is necessary to choose the proper mode of operation for your generator in order to get the best regulation and fastest response time possible.

To determine the proper connection for your generator you need to know any two of the following 3 specifications from the rating plate of your generator:

- 1: Exciter Field Voltage (in DC Volts) [Generally given in full load Voltage on nameplates]
- 2: Exciter Field Resistance (in Ohms) **[See Note Below]**
- 3: Exciter Field Amperage (in DC Amps) [Generally given in full load Amps on nameplates]

Using the specifications obtained from your generator exciter, select a Connection (A, B, or C) from the chart or graph below:

- Exciter field resistance is more than 40 ohms and exciter full load voltage is rated at 125vdc or less. **Use connection A (See Page 7)**
- Exciter field resistance is more than 21 ohms and exciter full load voltage is rated at 63vdc or less. **Use connection B (See Page 8)**
- Exciter field resistance is more than 10 ohms and exciter full load voltage is rated at 32vdc or less. **Use connection C (See Page 9)**

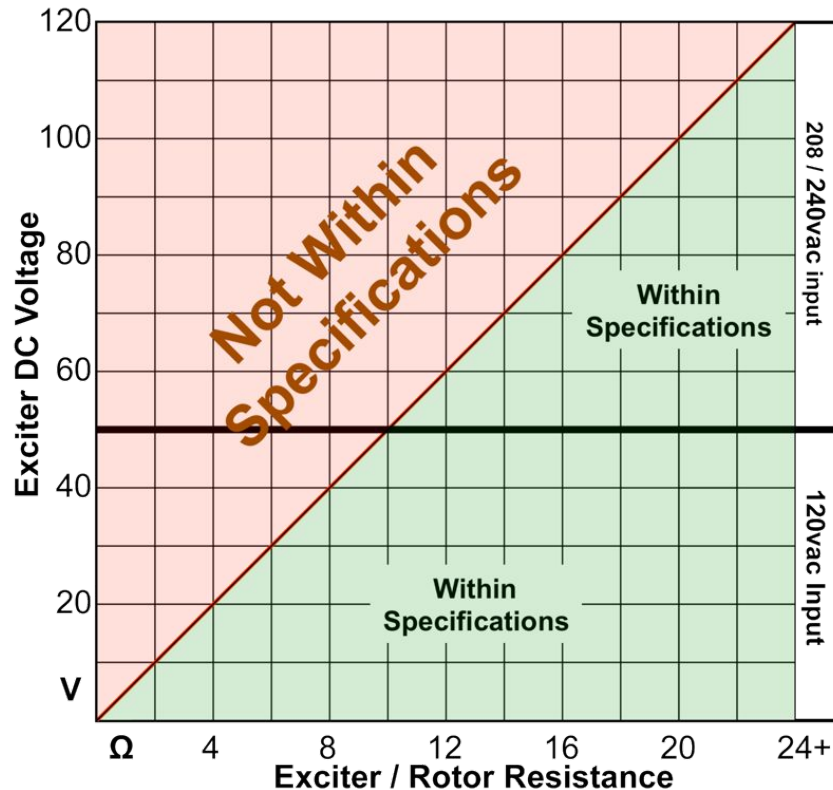



Note about Field Resistance:

- When measuring field resistance on a brushless generator, simply measure the resistance of the exciter field through your field leads with a multimeter.
- When measuring field resistance on a brush-type generator, measure the resistance through both the field leads as well as directly on the slip rings themselves. **The readings you obtain should ideally be the same, but no more than 1% difference.** If you show more than 1% difference in reading your generator has brush and ring contact problems and will need cleaning or maintenance before installing the XR500D. **Failure to correct brush and ring contact problems will result in severe damage to the voltage regulator as well as possible PERMANENT damage to the slip rings themselves!** NEVER use emery cloth, carborundum stones, “comm sticks”, or Tuner cleaner to dress or clean slip rings. They will make a bad problem much, much worse! Only use Garnet or Flint sandpaper and clean with a clean rag soaked with Acetone for best results!

If you do not have any of the specifications of your generator’s exciter, or if you don’t know where to start when trying to determine your exciter specs, please see the section below for instructions on measuring and calculating your exciter specifications.

- Measure your exciter field resistance using a multimeter on your field leads. Record this value. If you have a brush-type generator, also take a resistance reading on your slip rings: the value you obtain on the slip rings should be no more than 1% difference from the value you obtained through the field leads.
- Next, start and run the generator and apply 12V from a battery through your field leads and record the AC voltage produced by the generator. To determine your full load exciter field voltage, use the following formula:

$$E_{Exc.} = \frac{E_{Gen.Conf.}}{\left(\frac{E_{Gen.Output}}{E_{Battery}} \right)} * 2$$

Where $E_{Gen.Conf.}$ is your Generator’s configured voltage (e.g.: 120, 208, 240, 480V, etc.), $E_{Gen.Output}$ is your recorded output voltage, and $E_{Battery}$ is your battery voltage (12V usually).

- Next, calculate your maximum exciter field amperage using your measured field resistance and your calculated exciter voltage using the following formula:

$$I = \frac{E}{R}$$

Where I is your maximum exciter field current, E is your calculated field voltage from the above formula, and R is your measured field resistance.

Using the values you just measured and calculated, see the chart on the previous page to determine which connection you should use to connect the XR500D to your generator.



PMG, DPE Winding, Auxiliary Winding, and Harmonic/Resonant Winding Use

The XR500D Universal Voltage Regulator is compatible with some of these types of generators but not others. It is necessary to determine which type of generator you have before proceeding since some styles will connect differently than others while the XR500D cannot be used with some of these generators at all.

PMG (Permanent Magnet Generator/Exciter):

This type of generator generally has a permanent magnet generator mounted on the main shaft along with a brushless exciter and finally the main rotor itself. The XR500D is a very fast responding regulator (1/2 cycle response time) and low enough burden on the main stator that it can be used on these generators without any need for the PMG input.

To connect the XR500D to this type of generator, isolate and insulate the PMG leads that were connected to the original voltage regulator. Measure your field resistance and proceed with sizing on **Page 4**.

DPE Winding and Auxiliary Winding:

These generators use an extra winding in the main stator as a power supply for the voltage regulator in an attempt to give the regulator a clean power source that isn't affected by load. The XR500D has proprietary filtering circuitry in its sensing stage that is largely unaffected by generator load. Because the regulator isn't affected by loading, these types of windings are not needed.

To connect the XR500D to this type of generator identify, isolate, and insulate the Auxiliary or DPE wiring that were connected to the original voltage regulator. Measure your field resistance and proceed with sizing on **Page 4**.

Harmonic and Resonant Windings:

This type of generator rarely has a voltage regulator, and instead relies on a phase-shifted "harmonic" winding and a capacitor to adjust the terminal voltage with load. They often have a brushless "exciter", but because they operate on harmonics from the AC waveform, they do not operate like a typical brushless exciter.

Because these generators rely on AC waveform phasing for their voltage regulation, the XR500D cannot be used with this type of generator.



Connection A

(See page 11 if the generator will be paralleled using this connection)

Connection A is a Full-Wave rectified configuration, which allows a maximum of 210VDC at 5 ADC continuous with an input voltage of 240VAC.

This connection is typically used on higher voltage excitation fields (generally referred to as 125V fields) or on shunt control fields where the full-load excitation voltage is greater than 63VDC.

Note that the maximum input voltage to the XR500D Universal Voltage regulator is 240VAC! DO NOT input 277VAC into the XR500D! Severe damage to the unit will result! For use on 480V systems, either connect the regulator to the winding center taps T7 and T8 or use a 480-240V step-down transformer.

Connecting the input of the XR500D to 2 different legs of the generator as shown in the diagram below will result in greater regulation accuracy than when connecting line-neutral.

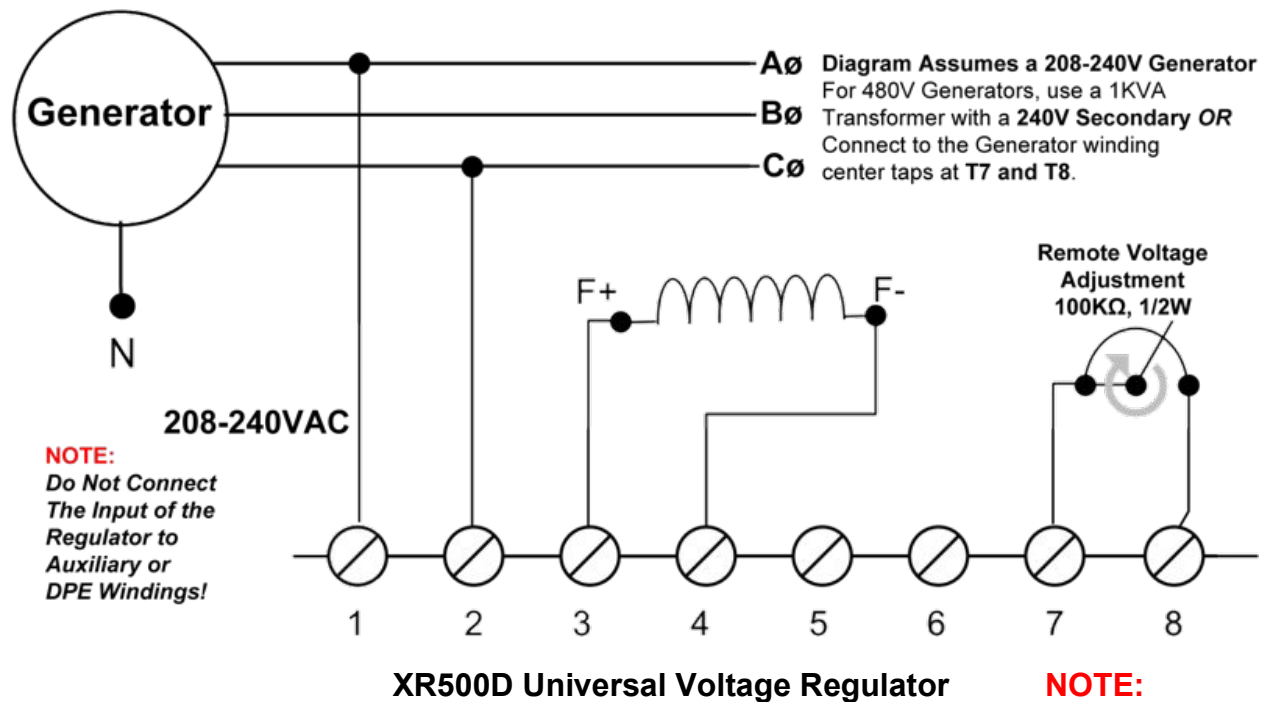

NOTE:

If the generator is to be operated below 50/60 Hz, a disconnect or switch should be installed in series with the incoming power to terminals #1 and #2 on the XR500D.

NOTE:

It is not necessary to jumper terminals 7 and 8 if not using the Remote Voltage Adjustment!

NEVER install a switch or breaker on the DC or Exciter side of the voltage regulator! Only install a switch or disconnect on the AC Side of the regulator!



Connection B

(See page 12 if the generator will be paralleled using this connection)

Connection B is a Half-Wave rectified configuration, which allows a maximum of 105VDC at 5 ADC continuous with an input voltage of 240VAC.

This connection is typically used on lower voltage excitation fields (generally referred to as 63V fields) and on brushless generator fields where the full-load excitation voltage is 63VDC or less.

Note that the maximum input voltage to the XR500D Universal Voltage regulator is 240VAC! DO NOT input 277VAC into the XR500D! Severe damage to the unit will result! For use on 480V systems, either connect the regulator to the winding center taps T7 and T8 or use a 480-240V step-down transformer.

Connecting the input of the XR500D to 2 different legs of the generator as shown in the diagram below will result in greater regulation accuracy than when connecting line-neutral.

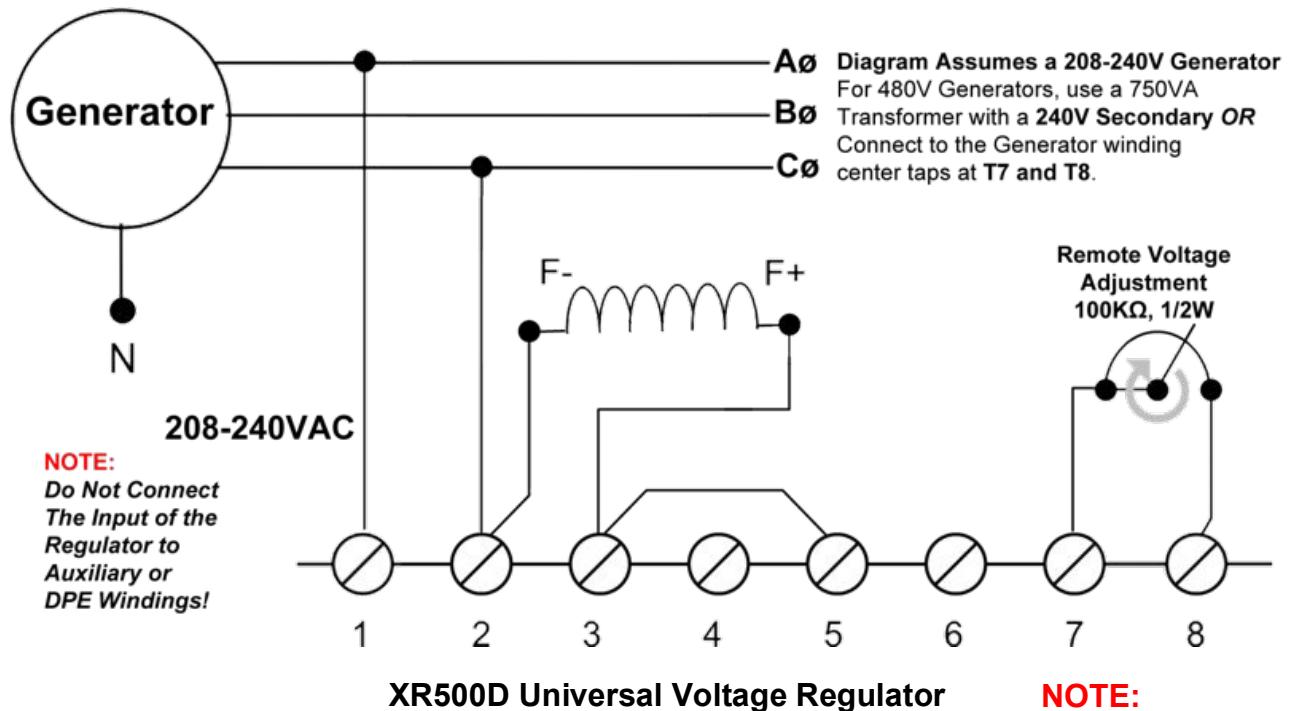

NOTE:

If the generator is to be operated below 50/60 Hz, a disconnect or switch should be installed in series with the incoming power to terminals #1 and #2 on the XR500D.

NOTE:

It is not necessary to jumper terminals 7 and 8 if not using the Remote Voltage Adjustment!

NEVER install a switch or breaker on the DC or Exciter side of the voltage regulator! Only install a switch or disconnect on the AC Side of the regulator!



Connection C

(See page 13 if the generator will be paralleled using this connection)

Connection C is a Half-Wave rectified configuration, which allows a maximum of 52VDC at 5 ADC continuous with an input voltage of 120VAC.

This connection is typically used on very low voltage excitation fields (generally referred to as 32V fields) and on brushless generator fields where the full-load excitation voltage is 32VDC or less.

Note that the maximum input voltage to the XR500D Universal Voltage regulator in this configuration is 139VAC! DO NOT input 208/240VAC into the XR500D in this configuration! Severe regulation problems and possible damage to the regulator or exciter field can result! For use on 480V systems, use a 480-120V step-down transformer.

Make sure Terminal #2 and F- from the exciter are connected to the Generator Neutral. Failure to verify this wiring before energizing the generator can result in severe damage or a voltage runaway condition!

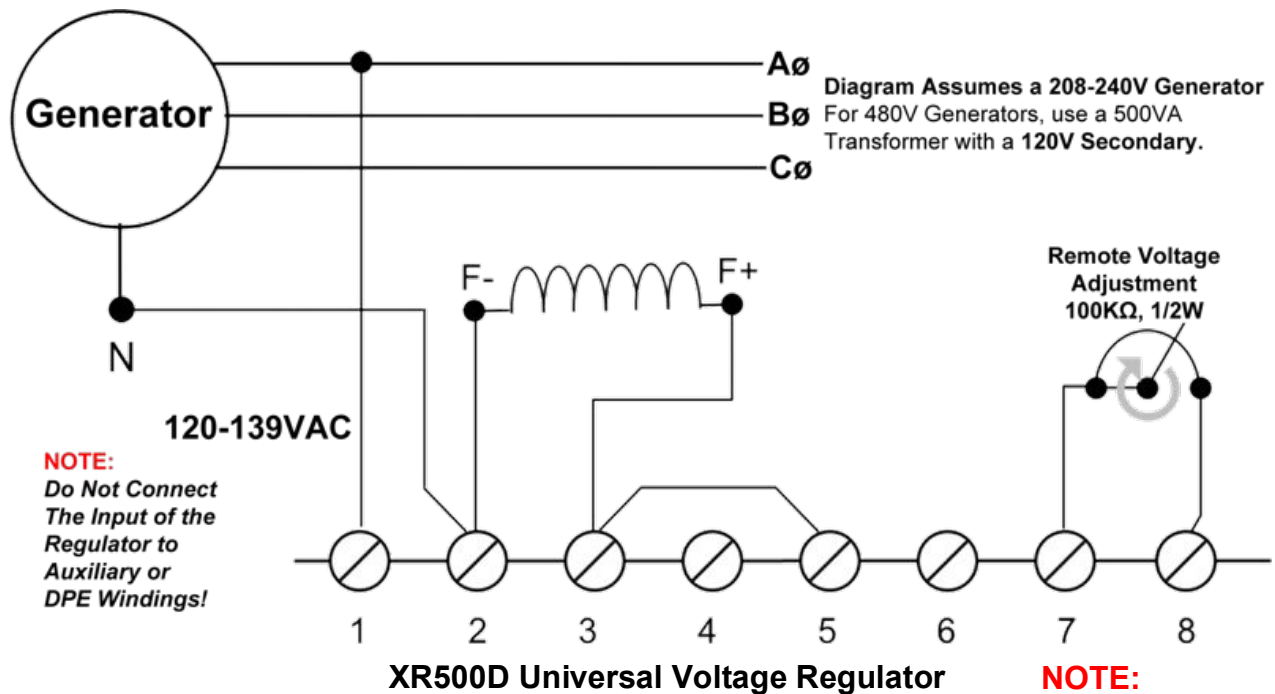

NOTE:

If the generator is to be operated below 50/60 Hz, a disconnect or switch should be installed in series with the incoming power to terminal #1 on the XR500D.

NOTE:

It is not necessary to jumper terminals 7 and 8 if not using the Remote Voltage Adjustment!

NEVER install a switch or breaker on the DC or Exciter side of the voltage regulator! Only install a switch or disconnect on the AC Side of the regulator!



Initial Setup and Commissioning

1. Install the regulator and wire up to the correct wiring diagram (Connection A, B, or C).
2. If installing the XR500D on a brush-type generator, verify that the brushes and brush riggings are isolated, ungrounded, and connected ONLY to the XR500D.
3. Turn the internal voltage control 15 or more turns counter clockwise (left) or until you hear the screw click. This procedure is necessary in case the original factory settings have been altered.



Internal
voltage
adjustment

Frequency Selection

Remove jumper for 50Hz operation. This product's default setting is 60Hz.

(Pull up to remove)

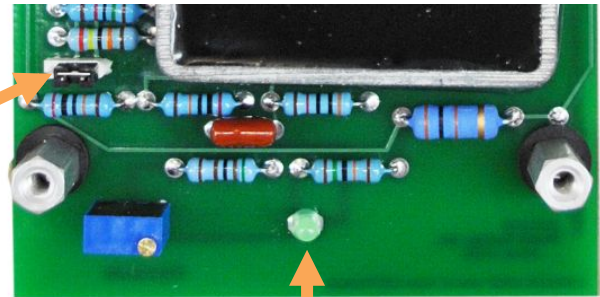

System
indicator light

4. If you are using a remote voltage adjustment, set it at 50% of adjustment.
5. If the generator is to be paralleled, set the droop resistor between 6Ω and 10Ω.
6. Start up the prime mover and bring up to operating speed and turn on the regulator switch (if used).
7. Set the internal voltage adjustment to the desired voltage setting for the generator output by turning the adjustment screw clockwise (right).
Note that the voltage adjustment is a 25-turn pot!
8. Place the generator on line and observe the frequency and voltage.
9. If the generator is being paralleled, measure the droop during loading and adjust the droop resistor as necessary. Reducing droop resistor resistance will reduce droop.
NOTE: Loading the generator with a purely resistive load-bank may cause undesirable droop characteristics such as no droop, very slight droop, or even rising terminal voltage. Measure droop with a mixed load for best results.
10. If paralleling and the terminal voltage rises or excessive amperage exportation occurs during loading with a mixed load connected, reverse the CT leads and try again.
11. Observe voltage regulation during no-load and full-load conditions. Once the voltage is set and regulating characteristics are satisfactory the installation procedure is complete.



Parallel Configuration for Connection A

To use the XR500D Universal Voltage Regulator in a parallel configuration either with another generator or with a buss such as a utility, use the diagram below for proper hookup with the XR500D configured for Connection A.

NOTE: Power-Tronics products parallel using the Reactive Droop compensation method. This allows our products to parallel with existing systems easily while also allowing islanded operation with the flip of a switch. When initially installing the droop resistor, set it for approximately 7Ω before final adjustment later. If the droop is excessive when load testing, reduce the resistance a bit at a time until satisfactory droop is achieved. **CT should be sized at 25VA or larger capacity!**

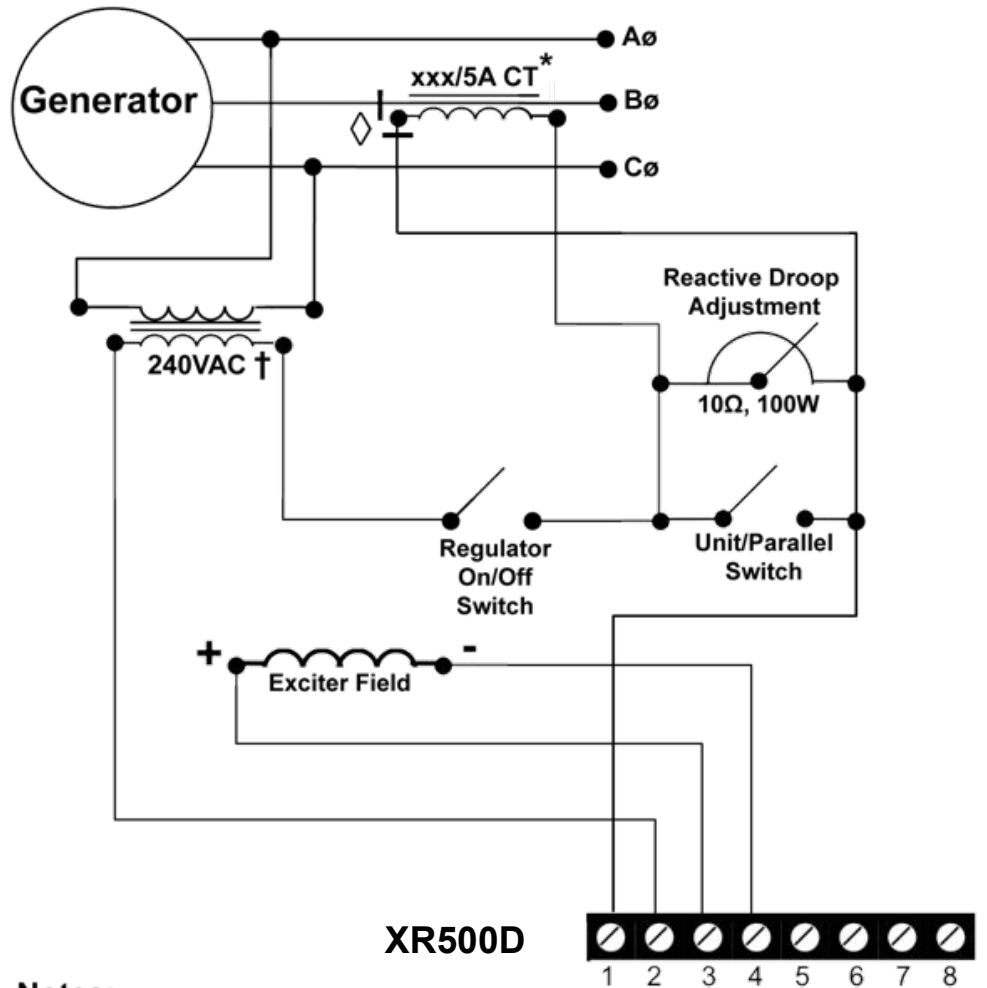

Notes:

† Transformer is optional.
Use a 1KVA Transformer for Full Output Amperage

* Size CT Primary as Closely to Generator Amperage as Possible for Best Droop Results

◇ If Generator Terminal Voltage Rises, or if Generator Exports VARS Excessively Under Load, Switch CT Leads at Regulator and Power Supply

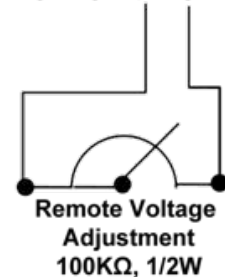



Parallel Configuration for Connection B

To use the XR500D Universal Voltage Regulator in a parallel configuration either with another generator or with a buss such as a utility, use the diagram below for proper hookup with the XR500D configured for Connection B.

NOTE: Power-Tronics products parallel using the Reactive Droop compensation method. This allows our products to parallel with existing systems easily while also allowing islanded operation with the flip of a switch. When initially installing the droop resistor, set it for approximately 7Ω before final adjustment later. If the droop is excessive when load testing, reduce the resistance a bit at a time until satisfactory droop is achieved. **CT should be sized at 25VA or larger capacity!**

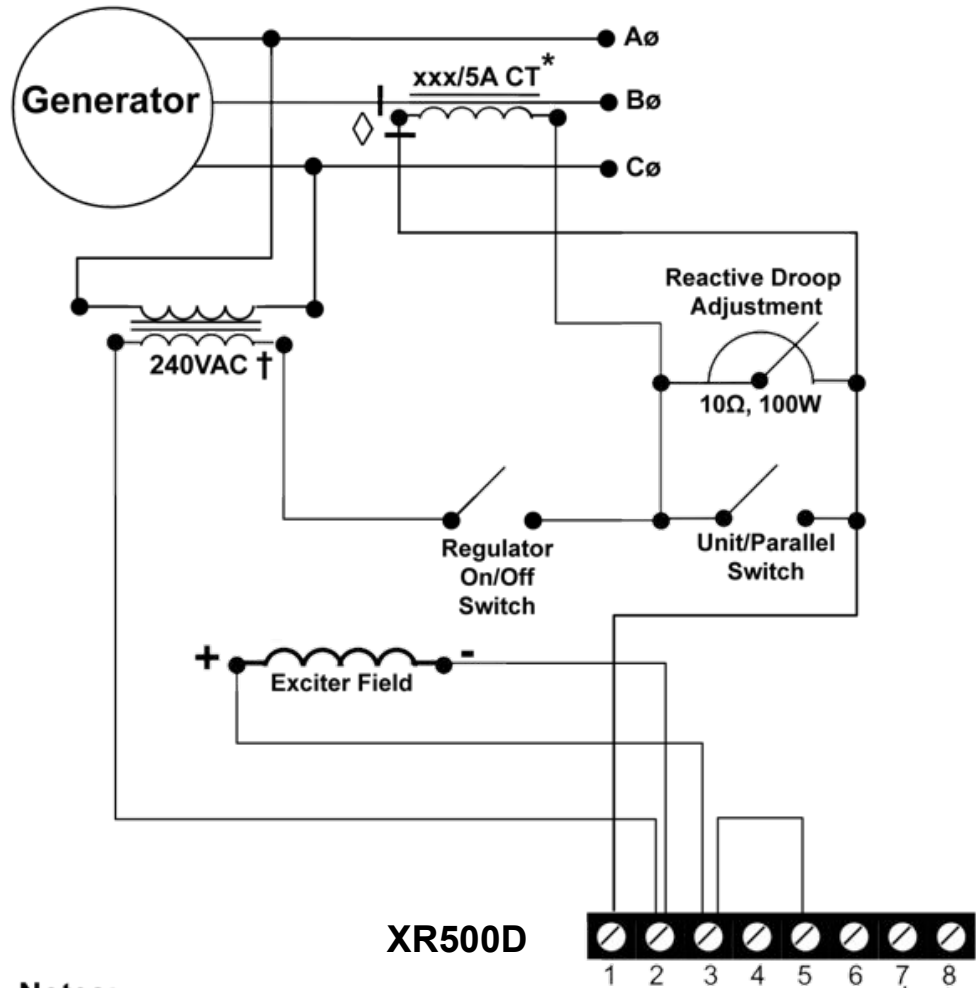

Notes:

† Transformer is optional.
Use a 750VA Transformer for Full Output Amperage

* Size CT Primary as Closely to Generator Amperage as Possible for Best Droop Results

◇ If Generator Terminal Voltage Rises, or if Generator Exports VARS Excessively Under Load, Switch CT Leads at Regulator and Power Supply

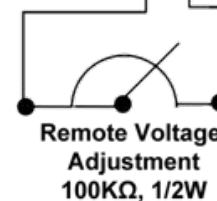



Parallel Configuration for Connection C

To use the XR500D Universal Voltage Regulator in a parallel configuration either with another generator or with a buss such as a utility, use the diagram below for proper hookup with the XR500D configured for Connection C.

NOTE: Power-Tronics products parallel using the Reactive Droop compensation method. This allows our products to parallel with existing systems easily while also allowing islanded operation with the flip of a switch. When initially installing the droop resistor, set it for approximately 7Ω before final adjustment later. If the droop is excessive when load testing, reduce the resistance a bit at a time until satisfactory droop is achieved. **CT should be sized at 25VA or larger capacity!**

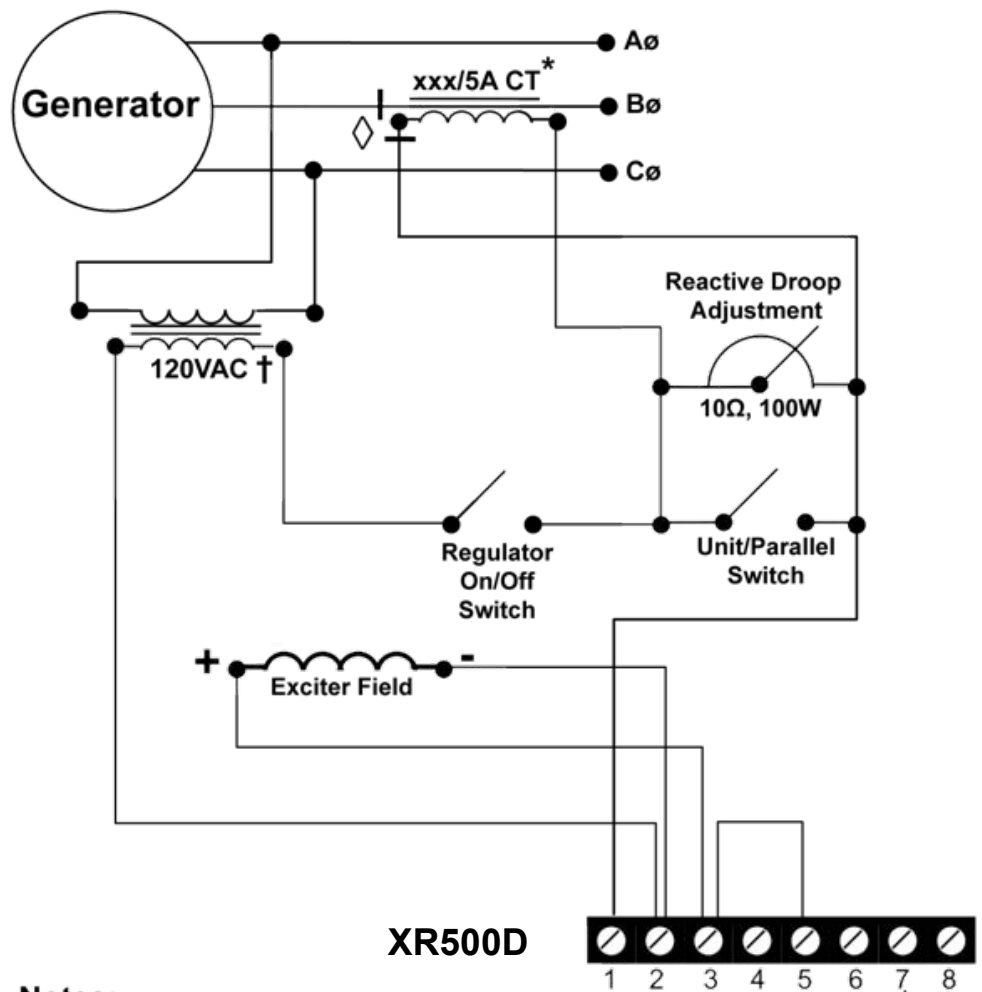

Notes:

† Transformer is optional.
Use a 500VA Transformer for Full Output Amperage

* Size CT Primary as Closely to Generator Amperage as Possible for Best Droop Results

◇ If Generator Terminal Voltage Rises, or if Generator Exports VARS Excessively Under Load, Switch CT Leads at Regulator and Power Supply

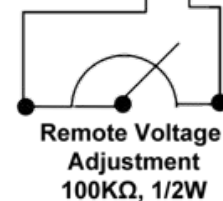



Optional Power-Tronics Add-On Modules

Power-Tronics offers a wide array of optional add-on modules for the XR series voltage regulators from static exciter modules to digital interface cards. For more information on any of the modules below, visit our online catalog at:

www.power-tronics.com



SE350

Static Exciter Module
Converts the XR500D into a 105VDC 30ADC Static Exciter!



SE450

Static Exciter Module
Converts the XR500D into a 210VDC 30ADC Static Exciter!



AFM500X

Automatic Flash Module
Adds Automatic Flash or Battery Flash to installations with low residual or requiring guaranteed buildup!



UIC200

Optical Interface Module
Allows the XR500D to be controlled externally by virtually any digital load-sharing controller, VAR controller, genset controller, or digital governor controller!

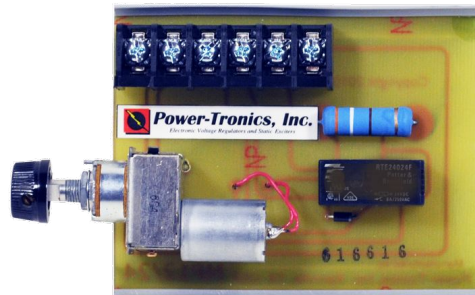

MP12/MP24

Motorized Potentiometer
Allows the XR500D to be externally controlled by older automated controllers using pulsed signals or dry contacts for control!



HVD1

High Voltage Disconnect Module
Saves your generator and connected equipment from runaway voltage conditions! Disconnects power to the voltage regulator instantly in the event of high voltage!



Conversion From Older Shunt-Wound Voltage Regulation to Modern Solid-State Voltage Regulation

It is possible to use the XR500D Universal Voltage regulator with older Shunt-Wound exciters that originally had manual or mechanical voltage regulators by converting the wiring as in the diagrams below. If the generator will not build up after conversion, try switching your F+ and F- leads at the regulator and try starting up again.

Original Wiring

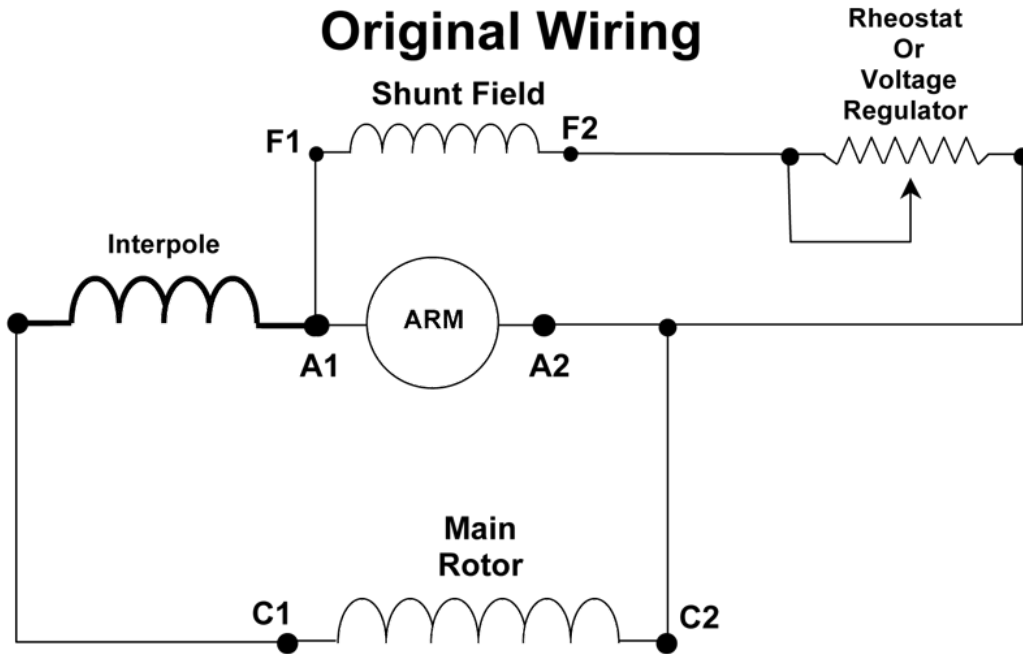

Converted Wiring

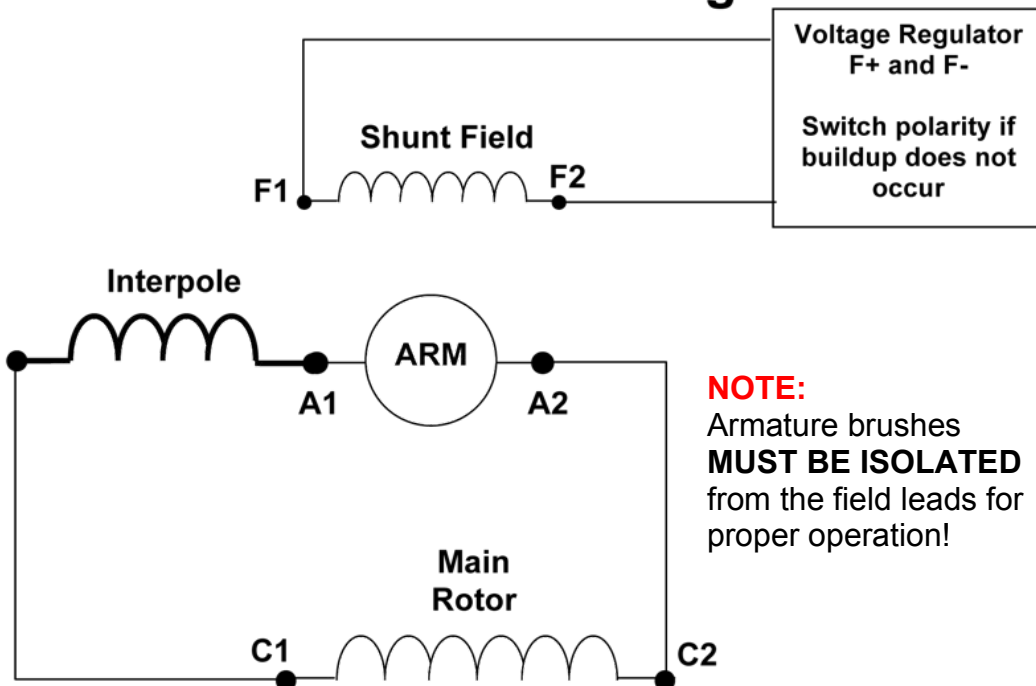



Fuse Replacement

The XR500D contains two 20mm cartridge fuses located for quick and convenient replacement should they blow. To replace the fuses, follow the instructions below.

Fuse size is 20mm x 5mm rated at 5A at 250VAC.

Power-Tronics Part Number: 5R3-403 (Comes as a package of 10 fuses)

Cooper-Bussmann Part Number: BK/GDB-5A

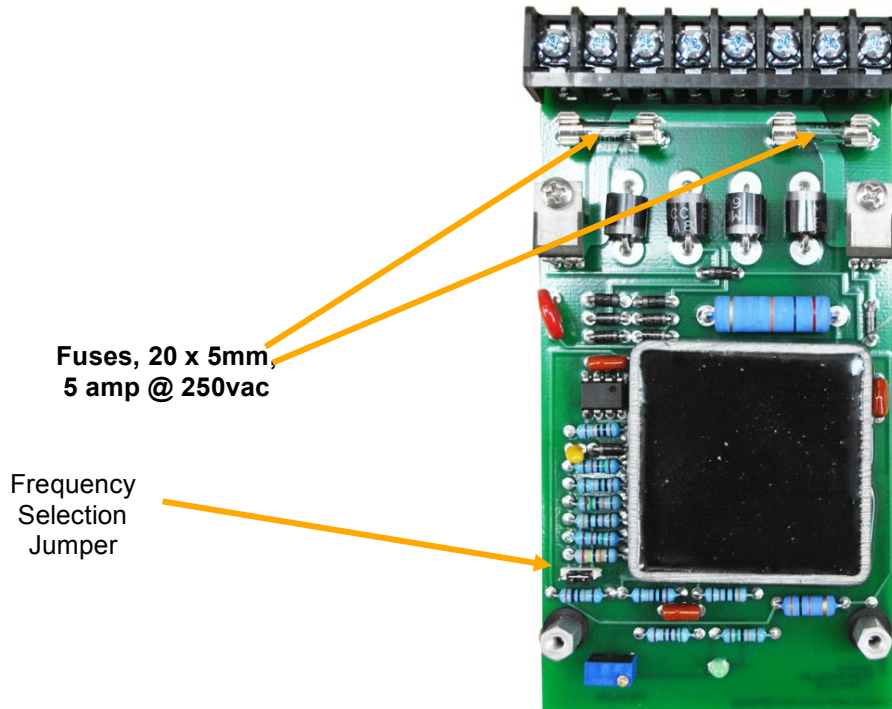

Fuse Replacement Procedure:

(Refer to the image above for easy reference)

- Remove the 2 screws located on the front of the mounting can near the terminal board.
- Loosen the 2 screws located on the front of the mounting can near the voltage adjustment hole. (There is no need to completely remove these screws!)
- Partially separate the top of the regulator printed circuit card from the mounting housing. (Separate just enough to reach in and replace the fuses.)
- Replace open fuses then replace and re-tighten all screws.
- Fuse size is 20mm x 5mm, 5A @ 250VAC. **(DO NOT REPLACE WITH ANY OTHER TYPE OR RATING OF FUSE! YOU WILL VOID YOUR WARRANTY AND SEVERE DAMAGE AND PERSONAL INJURY COULD RESULT BY DOING SO!)**



Application Troubleshooting

Problem:	Possible Cause
No Voltage	1 3 5 7 9 11 13 15 20
Pulsating Voltage	4 5 6 12 16
Flickering Voltage	4 6 7 14
High Voltage	6 7 8 9 12 13 17 18 20
Voltage Drop on Load	5 8 10 12 16
Low Voltage	5 8 12 13
Poor Voltage Regulation	2 4 10 12 13 16
No Voltage Control	13 19 20

Possible Causes:

1. Residual input voltage to the voltage regulator is below 3.5vac or fuses are open in the regulator.
2. Unbalanced generator load.
3. Open exciter field or defective generator.
4. Non linear load or defective connection in exciter field.
5. Open diode in exciter or shorted rotor in generator.
6. Loose component in voltage regulator.
7. Loose wiring connections.
8. Input voltage to regulator is too low.
9. Exciter field is grounded.
10. Non linear load or wrong selection for regulator hookup.
11. Exciter fields are reversed.
12. Wrong selection of regulator wiring configuration.
13. Defective voltage regulator.
14. SCR or Inverter drive effecting generator waveform.
15. Regulator needs external flashing circuit.
16. Isolation transformer is too small.
17. Isolation transformer is needed.
18. Exciter fields are not isolated from other circuits.
19. Input and field circuit are being fed by a common cable or conduit.
20. Incorrect hookup or wiring.



Bench Check Procedures

1. Wire up the regulator as shown in Figure A.
2. Connect up a 120 volt 50 to 150 watt light bulb to the F+ and F- Terminals.
3. Adjust the internal voltage pot fully CCW (25 turns) or until a click is heard.
4. Input 120vac into the regulator at #1 and #2. (Fuse this input with fuses rated at 120 volts or higher and not more than 5 amps ac)
5. **Observation:** The green status light should be on and the light bulb across F+ and F- should be off. **If the green status light is not on**, the internal fuses are blown in the regulator or there is internal damage to the regulator! **If the green status light is not on, do not continue this test!**
6. Turn the internal voltage adjustment CW until the light bulb across F+ and F- turns fully on, then adjust the internal voltage adjustment CCW until the light bulb is off.
7. Remove the 120vac from the regulator.
8. Connect up the regulator as shown in Figure B and perform all of the previous steps again. **In this mode, the light bulb will only glow at half brightness!**
9. **If you were able to successfully perform all of these tests, the regulator is good.**

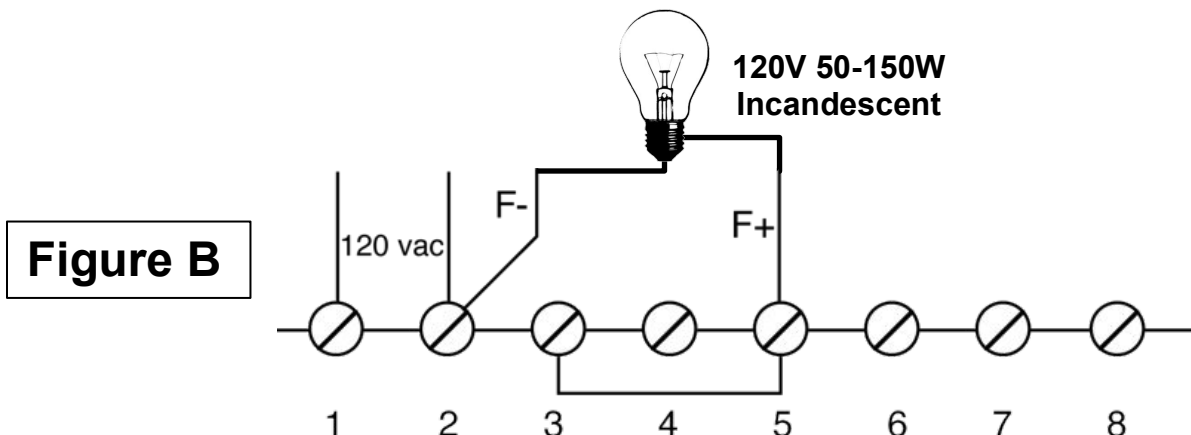
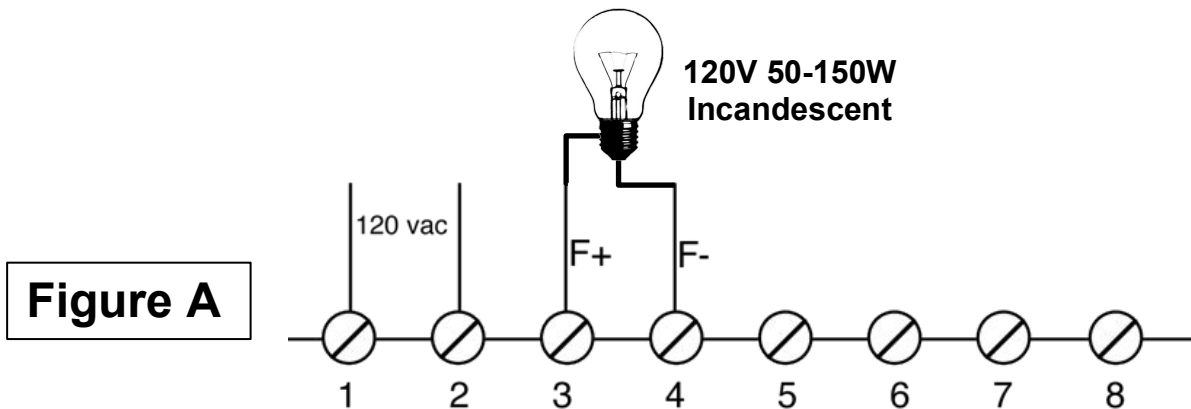



Installation Warranty Form

It is very important that you fill out this form completely when installing a voltage regulator. This form serves as a history record on the application. This form also contains the information needed by Power-Tronics, Inc., for repair and troubleshooting of any product you may be having problems with.

Failure to fill out this form during installation will result in a cancellation of your warranty coverage! Filling out this form takes only minutes but will save hours or days later on if your product should require service!

Product		Other options			
Serial Number					
Date of Installation					
Type of Generator				Model #	
	Brush type	[]			
	Brushless	[]			
AC Stator Information					
Wired for	Volts	Phase	Hz		
Generator Configuration: Lead					
Exciter/Rotor Information					
Exciter field resistance		Ω		@	F+ / F- Ω
Exciter field volts		vdc		@	Slip Rings Ω
Description of problem with product or generator					
Your phone number			Name:		
Your fax number			Ship to Address:		
Your email address			Ship to City, State, Zip:		



PRODUCT WARRANTY

Power-Tronics, Inc., assumes no liability for damages due to incorrect voltage or other voltage related damages resulting from either output of the generator or input to the generator exciter system. These problems should be protected with external devices provided by the customer such as **fuses, surge suppressors, over/under voltage and frequency controls.**

Power-Tronics, Inc., warrants **only parts and workmanship** of this product for a **period of 2 years from the original date of purchase from Power-Tronics, Inc.** Under warranty, Power-Tronics, Inc. will replace, exchange or repair the defective product **without labor or parts cost to the customer.** Remaining warranty of the original product will be transferred to the replaced or repaired product. To obtain warranty, a copy of the original Installation Warranty Form must be sent in with the defective product, which clearly shows the purchase date and serial number of the defective part. A repair request form must be sent in with the product before repairs will begin. You can obtain this form by contacting Power-Tronics, Inc.

Send repairs to: Power-Tronics, Inc., 2802 Cobbler Ln., Kerrville Texas USA 78028.

***Send in repairs only by UPS or FedEx.* USPS will NOT deliver to our facility!**

Any one of the following conditions will void the warranty:

- ❖ Overheating of the power supply resistor on the printed circuit card.
- ❖ Overheating of the SCR or freewheeling diode.
- ❖ Physical damage to the printed circuit card, housing or components.
- ❖ Unauthorized repair or alteration of printed circuit card.
- ❖ Installation by anyone other than a qualified professional generator service technician.
- ❖ Conductive or corrosive contamination of the circuit card.
- ❖ Removal of our company identification from the product.
- ❖ Removal of any conformal coating of the printed circuit card or components.
- ❖ Overheating of foil on the printed circuit card.
- ❖ Inappropriate or infeasible application.
- ❖ Use with any external device other than manufactured by Power-Tronics, Inc.
- ❖ Failure to fill out the attached warranty card during installation

No other warranty is expressed or implied.